



Regular Council Meeting  
May 26, 2026  
Executive Summary

Item #	Summary
9A-C	<p><b>Description:</b> Items for Action by Unanimous Consent</p> <p><b>Recommended Action:</b> Motion to approve the consent agenda as presented.</p>
10A	<p><b>Description:</b> Thornapple Meadows (formerly North Ridge Estates) Condominiums PUD Amendment, Final Amended Development Plan Review and First Reading of Ordinance 637</p> <p><b>Recommended Action:</b> Motion to approve the recommendation of the Planning Commission to amend the Thornapple Meadows (North Ridge Estates Condominiums Planned Unit Development and Final Amended Development Plan and conduct first reading of <b>Ordinance 637</b>, amending the Thornapple Meadows Condominiums Planned Unit Development.</p>
10B	<p><b>Description:</b> Parkinson's Pitch Event and Resolution 2026-10</p> <p><b>Recommended Action:</b> Motion to approve, under direction of staff, the request from Douglas Logan representing Parkinson's Pitch to hold a bean bag toss tournament on the soccer field in Fish Hatchery Park on <b>Saturday, August 1, 2026, from 10:00 AM to 6:00 PM</b>, and to adopt <b>Resolution 2026-10</b> staying the necessary ordinances to conduct the event.</p>



City of *Hastings* Michigan

(269) 945-2468  
FAX (269) 948-9544

201 E. State Street 49058

Item #	Summary
10C	<p><b>Description:</b> Dust Control on Gravel Streets</p> <p><b>Recommended Action:</b> Motion to approve the application of dust control on city gravel streets by Leaping Lizards in the amount of <b>\$6,100.</b></p>

**City Council Agenda**  
**May 26, 2026**

1. Regular meeting called to order at 7:00 PM
2. Roll call
3. Pledge to the flag
- √ 4. Approval of the agenda
- √ 5. Approval of the minutes of the May 11, 2026, regular meeting
- √ 6. Public Hearings:
  - \* A. North Ridge Estates Condominiums Planned Unit Development Modification and Final Site Plan Approval
7. Public Comment:
8. Formal Recognitions and Presentations: (None)
- √ 9. Items for Action by Unanimous Consent:
  - \* A. Consider approving, under the direction of staff, the request from Tanya Morse and Dave Bergstrom representing Kill the Mood Hastings Rockfest to sell merchandise and accept donations on **Saturday, August 8, 2026, from 5:00 PM to 9:00 PM**, at the Thornapple Plaza.
  - \* B. Consider approving, under the direction of staff, the request from the Barry County Chamber of Commerce to close Center Street from Broadway to Church Street on **Saturday, June 18, 2026, from 12:00 PM until 6:00 PM**, to conduct the 2026 Barry County Brewfest event at the Barry Community Foundation parking lot.
  - \* C. Receive and place on file fourteen (14) invoices totaling **\$1,005,283.90**.
- √ 10. Items of Business:
  - \* A. Consider approving the recommendation of the Planning Commission to amend the Thornapple Meadows (North Ridge Estates) Condominiums Planned Unit Development and Final Amended Development Plan and conduct first reading of **Ordinance 637**, amending the Thornapple Meadows Condominiums Planned Unit Development.

- \* B. Consider approving, under direction of staff, the request from Douglas Logan representing Parkinson’s Pitch to hold a bean bag toss tournament on the soccer field in Fish Hatchery Park on **August 1, 2026, from 10:00 AM to 6:00 PM,** and adopting **Resolution 2026-10** staying the necessary ordinances to conduct the event.
  - \* C. Consider approving the application of dust control on city gravel streets by Leaping Lizards in the amount of **\$6,100.**
  - 11. Staff Presentations and Policy Discussions (None)
  - 12. City Manager Report:
    - \* A. Police Chief Boulter Monthly Report
    - \* B. City Clerk/Treasurer Perin Monthly Financial Reports
    - \* C. Community Development Director King Monthly Report
  - √ 13. Reports and Communications: (None)
  - 14. Public Comment:
  - 15. Mayor and Council comment:
  - √ 16. Adjourn
- \* Items with enclosures.  
 √ Motion under agenda heading requires roll call vote.

Guidelines for Public Comment

Public Comment is welcomed and appreciated. Please follow these simple guidelines to ensure all have an opportunity to be heard.

All comments and questions will be made through the chair. All comments will be made in a courteous and civil manner; profanity and personal attacks will not be tolerated. Please limit the length of your comments to 3 minutes. If you are a member of a group, please appoint a spokesperson to speak on behalf of the group (those speaking on behalf of a group may be provided additional time). Please state your name before offering comment.

**City of Hastings**  
COUNTY OF BARRY, STATE OF MICHIGAN

---

**City Council Meeting Minutes**  
**May 11, 2026**

1. Regular meeting called to order at 7:00 PM
2. Roll call

Councilmembers Present: Bergeron, Brehm, Devroy, McLean, Resseguie, Rocha, Stenzelbarton and Tossava

Councilmember Absent: Barlow

City Staff and Appointees Present: Moyer-Cale, Boulter, Jordan, King, Neil and Perin
3. Pledge to the flag
4. Approval of the agenda:

Motion by Stenzelbarton, with support from Devroy, to approve the agenda as presented.  
All ayes. Motion carried.
5. Approval of the minutes:
  - A. Approval of the minutes of the April 27, 2026, workshop meeting.

Motion by Rocha, with support from Devroy, to approve the minutes of the April 27, 2026, workshop meeting as presented.

Ayes: Bergeron, Brehm, Devroy, McLean, Resseguie, Rocha, Stenzelbarton and Tossava  
Nays: None  
Absent: Barlow  
Motion carried.
  - B. Approval of the minutes of the April 27, 2026, regular meeting.

Motion by Stenzelbarton, with support from McLean, to approve the minutes of the April 27, 2026, regular meeting as presented.

Ayes: Bergeron, Brehm, Devroy, McLean, Resseguie, Rocha, Stenzelbarton and Tossava  
Nays: None  
Absent: Barlow  
Motion carried.

## 6. Public Hearings:

## A. Proposed 2026/2027 Fiscal Year Budget and Millage Rates:

City Manager explained changes to the budget from the version at the Budget Workshop. Discussion on operating and cemetery millages.

Public Hearing Open: 7:09 PM

No public comments.

Public Hearing Closed: 7:09 PM

## B. Final Assessment Roll for parking in the City of Hastings Principal Shopping District for Fiscal Year 2026/2027:

City Manager gave an overview of the assessment and answered Council questions.

Councilmembers Rocha, Devroy and Stenzelbarton made comments against the Assessment.

Public Hearing Open: 7:17 PM

Comments from Phillip Joseph, who owns three downtown properties, and appreciates the Council members' comments to reduce or eliminate the SAD and support of local businesses.

Public Hearing Closed: 7:19 PM

## 7. Public Comment: (None)

## 8. Formal Recognitions and Presentations:

## A. Eric Thompson, Professional Code Inspectors, presented on advancements made at PCI and answered questions from the Council.

Discussion was held.

## 9. Items for Action by Unanimous Consent:

## A. Consider accepting, with regret, the resignation of Carole Davis from the Brownfield Redevelopment Authority, effective Wednesday, July 1, 2026, and to send her a letter of thanks.

Motion by McLean, with support from Devroy, to accept, with regret, the resignation of Carole Davis from the Brownfield Redevelopment Authority, effective Wednesday, July 1, 2026, and send her a letter of thanks.

Ayes: Bergeron, Brehm, Devroy, McLean, Resseguie, Rocha, Stenzelbarton and Tossava

Nays: None

Absent: Barlow  
Motion carried.

- B. Consider approving, under the direction of staff, the American Legion Post 45 to conduct the annual Memorial Day Parade at **9:30 AM on Monday, May 25, 2026.**

Motion by Rocha, with support from McLean, to approve, under the direction of staff, the American Legion Post 45 to conduct the annual Memorial Day Parade at **9:30 AM on Monday, May 25, 2026.**

Ayes: Bergeron, Brehm, Devroy, McLean, Resseguie, Rocha, Stenzelbarton and Tossava

Nays: None

Absent: Barlow

Motion carried.

- C. Consider approving, under the direction of staff, the request from the Hastings Business Connection to conduct three (3) separate Block Party-Street Dances from **5:30 PM until 11:00 PM on Saturday, June 20, 2026; Saturday, July 18, 2026, and Saturday, August 15, 2026,** and consent to street closures on the respective dates.

Motion by Stenzelbarton, with support from Brehm, to approve, under the direction of staff, the request from the Hastings Business Connection to conduct three (3) separate Block Party-Street Dances from **5:30 PM until 11:00 PM on Saturday, June 20, 2026; Saturday, July 18, 2026, and Saturday, August 15, 2026,** and consent to street closures on the respective dates.

Discussion was held, with Brian Reynolds addressing Council questions.

Ayes: Bergeron, Brehm, Devroy, McLean, Resseguie, Rocha, Stenzelbarton and Tossava

Nays: None

Absent: Barlow

Motion carried.

- D. Consider upholding the disclosure denial issued by the City Police Department on or about April 8, 2026, in response to the Freedom of Information Act request submitted by Jeffrey Allen Snowden II and to certify that the statements in the response to the request are accurate, and the documents being produced, redacted and/or withheld comply with the City's publicly available FOIA procedures and guidelines. The City Clerk is directed to notify the requester, in writing, of the City Council's determination on this appeal within 10 business days.

Motion by McLean, with support from Devroy, to uphold the disclosure denial issued by the City Police Department on or about April 8, 2026, in response to the Freedom of Information Act request submitted by Jeffrey Allen Snowden II and to certify that the statements in the response to the request are accurate, and the documents being produced, redacted and/or withheld comply with the City's publicly available FOIA procedures and guidelines. The City Clerk is directed to notify the requester, in

writing, of the City Council's determination on this appeal within 10 business days.

Discussion was held.

Ayes: Bergeron, Brehm, Devroy, McLean, Resseguie, Rocha, Stenzelbarton and Tossava

Nays: None

Absent: Barlow

Motion carried.

10. Items of Business:

- A. Consider adopting **Resolution 2026-07** to approve the final assessment roll for the fiscal year 2026-2027 special assessment district for parking improvements in the downtown principal shopping district.

Motion by McLean, with support from Resseguie, to adopt **Resolution 2026-07** to approve the final assessment roll for the fiscal year 2026-2027 special assessment district for parking improvements in the downtown principal shopping district.

Ayes: Resseguie and Tossava

Nays: Bergeron, Brehm, Devroy, McLean, Rocha and Stenzelbarton

Absent: Barlow

Motion not carried.

- B. Consider approving, under the direction of staff, the Hastings Summerfest Committee's request to hold the annual Summerfest celebration on **August 28, 29, and 30, 2026**, in Fish Hatchery Park, Tyden Park, Parking Lots #4 and 5, various streets, the Spray Plaza, and Thornapple Plaza, and adopting **Resolution 2026-08** to stay the necessary ordinances to conduct the event.

Motion by Stenzelbarton, with support from Devroy, to approve, under direction of staff, the Hastings Summerfest Committee request to hold the annual Summerfest celebration on **August 28, 29, and 30, 2026**, in Fish Hatchery Park, Tyden Park, Parking Lots #4 and 5, various streets, the Spray Plaza, and Thornapple Plaza, and adopt **Resolution 2026-08** to stay the necessary ordinances to conduct the event.

Discussion was held.

Ayes: Bergeron, Brehm, Devroy, McLean, Resseguie, Rocha, Stenzelbarton and Tossava

Nays: None

Absent: Barlow

Motion carried.

- C. Consider adopting **Resolution 2026-09** to enact the General Appropriations Act for the Fiscal Year 2026-2027, and to approve the operating budgets for said year, and to establish the property tax millage rates to support the budget.

The city manager specified that because the parking special assessment was not

approved, the equivalent revenue needed to be reduced from the budget.

Motion by Rocha, with support from Stenzelbarton, to adopt **Resolution 2026-09** to enact the General Appropriations Act for the Fiscal Year 2026-2027, and to approve the operating budgets for said year, and to establish the property tax millage rates to support the budget, with the amendment to eliminate the special assessment district revenue.

Ayes: Bergeron, Brehm, Devroy, McLean, Resseguie, Rocha, Stenzelbarton and Tossava

Nays: None

Absent: Barlow

Motion carried.

- D. Consider authorizing the City Clerk to execute the Bilateral METRO Act Permit for right-of-way telecommunications with Surf Air Wireless, LLC.

Motion by Rocha, with support from Stenzelbarton, to authorize the City Clerk to execute the Bilateral METRO Act Permit for right-of-way telecommunications with Surf Air Wireless, LLC.

Discussion was held.

Ayes: Bergeron, Brehm, Devroy, McLean, Resseguie, Rocha, Stenzelbarton and Tossava

Nays: None

Absent: Barlow

Motion carried.

- E. Consider approving the proposal from Hickey Electric, Inc. for electrical and control upgrades to the wastewater alum feed system in the amount of **\$7,215**.

Motion by McLean, with support from Devroy, to approve the proposal from Hickey Electric, Inc. for electrical and control upgrades to the wastewater alum feed system in the amount of **\$7,215**.

Discussion was held.

Ayes: Bergeron, Brehm, Devroy, McLean, Resseguie, Rocha, Stenzelbarton and Tossava

Nays: None

Absent: Barlow

Motion carried.

- F. Consider approving the proposal from AllMax Software for setup and implementation of the Antero asset management database in the amount of **\$10,000**.

Motion by McLean, with support from Devroy, to approve the proposal from AllMax Software for setup and implementation of the Antero asset management database in the amount of **\$10,000**.

Discussion held.

Ayes: Bergeron, Brehm, Devroy, McLean, Resseguie, Rocha, Stenzelbarton and Tossava

Nays: None

Absent: Barlow

Motion carried.

- G. Consider approving the C&L Concrete Construction bid in the amount not to exceed **\$80,402.50**.

Motion by Stenzelbarton, with support from McLean, to approve the C&L Concrete Construction bid in the amount not to exceed **\$80,402.50**.

Ayes: Bergeron, Brehm, Devroy, McLean, Resseguie, Rocha, Stenzelbarton and Tossava

Nays: None

Absent: Barlow

Motion carried.

- H. Consider executing the Memorandum of Understanding with Hastings Rotary as presented.

Motion by McLean, with support from Devroy, to execute the Memorandum of Understanding with Hastings Rotary as presented.

Discussion was held regarding the proposed skate park.

Ayes: Bergeron, Brehm, Devroy, McLean, Resseguie, Rocha, Stenzelbarton and Tossava

Nays: None

Absent: Barlow

Motion carried.

11. Staff Presentations and Policy Discussion: (None)

12. City Manager Report:

- Assistant City Manager has been working on preparing documents to apply for the Safe Streets for All Grant. Does Council want to approve a \$40,000 matching grant? If not, there is no reason to work to apply for the grant.

Discussion held.

It was the consensus of Council to proceed with the application.

- Utilities Superintendent position posted on website – applications accepted through May 26, 2026.
- Rob Neil provided an update on Truck #70 repairs, including additional costs.

- A. Fire Chief Jordan Monthly Report
- B. Library Director Edelman Monthly Report
- C. Utilities Superintendent Robins Monthly Report

13. Reports and Communications:

- A. YMCA Updates for the City of Hastings – April 2026

Motion by Stenzelbarton, with support from Devroy, to accept and place on file item A.  
All ayes. Motion carried.

14. Public Comment: (None)

15. Mayor and Council comment:

Comments from Mayor Tossava, mentioning that 12 students from St. Rose School will tour City Hall on Tuesday, May 12, 2026.

16. Adjourn:

Motion by McLean, with support from Devroy, to adjourn.  
All ayes. Motion carried. Meeting adjourned at 8:20 PM.

Read and Approved:

---

David J. Tossava, Mayor

---

Linda Perin, City Clerk



# Regular Council Agenda Item Memorandum

**To:** Mayor Tossava and City Council

**From:** Dan King

**Subject:** Kill the Mood Hastings Rockfest

**Meeting Date:** May 26, 2026

---

## Recommended Action:

Motion to approve, under the direction of staff, the request from Tanya Morse and Dave Bergstrom representing Kill the Mood Hastings Rockfest to sell merchandise and accept donations on **Saturday, August 8, 2026, from 5:00 PM to 9:00 PM**, at the Thornapple Plaza.

## Background Information:

Kill the Mood is a Barry County band consisting of 18-year-olds who have already toured with national bands. *Kill the Mood* has hosted events in the past year at Delton Kellogg High School and the Hastings Performing Arts Center.

Per Section 58-82 (j) of the Municipal Code as follows: No vending or solicitation of funds is permitted at an entertainment venue without approval of the City Council.

## Financial Implications:

None

## Attachments:

- Request Letter

May 12, 2026  
City Council  
City of Hastings  
201 E State St  
Hastings MI 49058

Dear Members of the Council,

Kill The Mood a Barry County Band of 18 year olds, who have already Toured with National Bands and also hosted events this past year at Delton High School, The Hastings Performing Arts Center and more, would like to Host another Barry County Event "Kill The Mood's Hastings RockFest on August 8th 2026 from 5pm to 9pm at the Thornapple Plaza and we are requesting the following:

1. To be able to bring a total of (2-4) 8 foot tables and Sell band t shirts and other band merch paying to the bands to help with there costs.
2. To be able to sell our own Concessions consisting of the following Bottled Water, Chips and Pop from our merch tables for \$1-2 each. We expect around 100 people and this would help our event with the costs of putting this on for the community.
3. To be able to have a band tip bucket for bands playing.

This is a Fun, Free, All Ages Grass Roots event for the community where we plan to have 2-3 Michigan bands playing around 3 Hours on stage. Kill The Mood will Headline the event and is releasing their 1st album at this show! We hope this is the 1st of many events in Hastings!

Thank you for your consideration of this request. Should you have any questions regarding this event please do not hesitate to contact Dave Bergstrom Kill The Mood Management (The Drummers Dad) at [REDACTED]

Best Regards  
Kill The Mood  
Tanya Morse Hastings,MI (Mom of KTM singer)  
Dave Bergstrom Manager (Dad of KTM Drummer)



# Regular Council Agenda Item Memorandum

**To:** Mayor Tossava and City Council

**From:** Dan King

**Subject:** Barry County Chamber of Commerce 2026 Barry County Brewfest

**Meeting Date:** May 26, 2026

---

## Recommended Action:

Motion to approve, under the direction of staff, the request from the Barry County Chamber of Commerce to close Center Street from Broadway to Church Street on **Saturday, July 18, 2026, from 12:00 PM until 6:00 PM**, to conduct the 2026 Barry County Brewfest event at the Barry Community Foundation parking lot.

## Background Information:

The Barry County Chamber of Commerce will be hosting the 10<sup>th</sup> annual Barry County Brewfest in the parking lot of the Barry Community Foundation at 231 S. Broadway. Historically the event draws 400 to 600 people and is highly anticipated. The closure of Center Street from Broadway to Church Street will provide additional security and safety for the event.

## Financial Implications:

There are no financial implications for the City.

## Attachments:

- Request Letter and Special Event Application

# BARRY COUNTY

CHAMBER & ECONOMIC DEVELOPMENT ALLIANCE

138 W. State Street  
Hastings, MI 49058

May 20, 2026

Hon. David Tossava  
City Council Members  
201 E. State St.  
Hastings, MI 49058

Re: 2026 Barry County Brewfest

Dear Mayor Tossava and Members of City Council:

As you're likely aware, the Barry County BrewFest – which enjoyed a successful ninth annual event in Nashville this past August – is an event that is set up to draw visitors to the community from throughout Barry County and from outside county borders as well. It certainly accomplishes that on an annual basis, attracting attendees from all over the region.

When the Barry County Chamber of Commerce launched this brand-new event in the summer of 2016, it was done so with the unique premise of traveling to a different Barry County community each year. We feel this not only adds to the uniqueness of the event and keeps it fresh from one year to the next, but also tangibly demonstrates our organization's commitment to engaging throughout Barry County.

We would love to host our tenth annual Barry County Brewfest in downtown Hastings; at the Barry Community Foundation parking lot.

After discussions with the BCF staff, we have identified the date of Saturday, July 18, 2026, as the proposed date for the event.

Attached is a draft layout of the proposed event footprint. While some nuts & bolts details still need to be ironed out, our team, the BCF Staff and City Staff are on the same page that we can make this work and will be a great addition to the Downtown Hastings schedule of events in 2026.

We've hovered right around 600-1000 attendees in the last few years for Brewfest. Considering the larger size of Hastings, the destination venue and extra push of it being the 10<sup>th</sup> annual event, we could possibly push double that attendance this year.

Some key items to consider with this request:

- Setup of the event would occur the morning of the event on 7/18, and the event would be largely torn down the evening of the 18<sup>th</sup>. Some larger items such as the tent and refrigerated trailer(s) might not be picked up until Sunday 7/19 or the early morning of 7/21.
- While we are proposing that Center Street be closed between Church and Broadway.
- We would work with the City Police Department and Reserves to ensure appropriate law enforcement presence throughout the event.
- The proposed hours of operation of the event are 12pm-6pm. In my experience, we have very few issues when events like this are wrapped up before dark.

- We realize that parking will be an important detail to work out in advance of the event. We have reached out to Green Street United Methodist Church and Highpoint Community Bank and hope to arrange paid parking for them or a non-profit of their choice.
- We do not anticipate much labor hours needed from City DPW in support of this event. Even so, any incurred will be reimbursed from the Chamber.
- Anchor dining establishments downtown such as the Walldorff Brewpub are in support of this request. Letters can be secured if desired.
- Our Brewfest event is well-managed and we have very few – if any – issues. I am happy to refer you to any of our municipal partners from the last four years for their perspective of hosting the event in their community. We are routinely asked when is the soonest opportunity for us to “bring Brewfest back.”

At this time, the Barry County Chamber of Commerce is seeking permission and confirmation from City Council to host the 2026 Barry County BrewFest event at the Barry Community Foundation parking lot on July 18, 2026.

On behalf of our organization and all BrewFest supporters, I appreciate your consideration of this request. Your response will help us to begin early promotion of the event and kick-start our event planning in earnest. Should you have questions regarding this request, please do not hesitate to contact me at 269-945-2454.

Kindest regards,

Kim Martin

*Business Manager, Barry County Chamber of Commerce & Economic Development Alliance*



## City of Hastings Special Event Application

The City of Hastings values the unique events and gatherings that make our community special. The City has created this application form to help organizations provide adequate information for their requests to be considered. Please contact the Community Development Department with any questions or concerns about this form.

### Section 1: Applicant/Organization Information

Barry County Chamber [REDACTED]  
Applicant/Organization Name Phone

Kim Martin [REDACTED] [REDACTED]  
Contact Name Phone Email

138 W. State St Hastings MI 49058  
Street City State Zip

Kim Martin [REDACTED]  
Contact person on day of event (if different than above) Phone

### Section 2: Event Information

Barry County Brewfest  
Name of Event

Craft Beer Tasting Event  
Description of Event

7-18-24 Noon - 6PM  
Event Dates Time (From/To)

7/18/24 7:30 AM 7/18/24 6:00 PM  
Set up Date(s) and Time(s) Clean up Date(s) and Time(s)

BCE Parking lot  
Location(s) of Event

85 Estimated number of volunteers  
500-800 Estimated daily attendance (if known)

**Section 3: Event Details**

Please indicate if any of the following will be a part of your event area:

- Road closure Center Street between Church + Broadway
  - If checked, please provide a proposed detour route.
- Closure of public parking area
- Use of park area
- Firepits/open flame
- Fireworks or pyrotechnics
  - If yes, provide a copy of liability insurance listing the City as an additional insured party.
- Food and/or non-alcoholic beverage service or sales (if yes, contact Barry County Health Department)
  - If yes, provide copy of Health Department Food Service License
- Temporary structures (including tents or pavilions)
- Music
  - If yes, what time will music begin and end? Noon - 6:00 PM
  - If yes, what type of music is proposed? Live - Acoustic Live - Amplification Recorded Loudspeakers or public address system
- Parade
- Race (ex: 5K)
- Vendors/sale of goods
- Carnival rides
  - If yes, provide a copy of liability insurance listing the City as an additional insured party.
- Signs or banners
- Animals/petting zoo
- Portable restroom facilities
- Donation collection/free will offering
- Other \_\_\_\_\_
- Alcohol
  - If yes, provide copy of liquor liability insurance with the City listed as an additional insured.
  - If yes, provide a copy of Michigan Liquor Control License Application.
  - If yes, describe measures to be taken to prohibit the sale of alcohol to minors (use separate pages if necessary).
  - If the alcohol is being served in the Social District, a Council Resolution suspending the district is required.

Please describe how garbage will be managed?

We have a dumpster that will be in the  
BCF Lot company will pick up.

**Section 4: Site & Event Plan**

Please prepare a site plan that includes the following information:

Location of all temporary structures, food/concessions, booths, portable restrooms, road closures, barricades, music, event signage, garbage cans, and other event locations. Include location of exit pathways.

**Section 5: Acknowledgements and Hold Harmless Agreement**

The Applicant understands and agrees to the following:

1. This application is subject to review by various city departments and must be approved by the City Council. Failure to submit this application in a timely manner may delay approval or result in the denial of the application. Submission of the application does not guarantee an approval. The City may require conditions on the approval of any application.
2. The applicant must comply with all local and applicable state laws and policies. The Applicant acknowledges that approval of the special event does not relieve the applicant from meeting any requirements of law or those of other bodies or agencies applicable to the event.
3. The Applicant agrees to clean up and restore the area in the condition it was found prior to the event. The City is not responsible for equipment or personal items left on public property.
4. The Applicant acknowledges that they shall not discriminate against any employee or applicant for employment because race, color, religion, sex, national origin, age, disability, or any other applicable status protected by federal, state, or local law. The Applicant further agrees that it will comply with the Civil Rights Act of 1973, as amended, and the Michigan Civil Rights Act of 1976 (78. Stat 252 and 1976 PA 453) and will require the same of any consultant or sub-contractor involved in hosting the event.
5. Upon approval of the event, the Applicant agrees to fully defend, indemnify and hold harmless the City, its City Council, its officers, employees, agents, volunteers, and contractors from any and all claims, demands, losses, obligations, costs, expenses, verdicts, and settlements (including but not limited to attorney fees and interest) resulting from any act or omission by the applicant, its agents, employees, contractors, and volunteers, and violation of state or federal law, and any other acts of the applicant or attendees causing personal injury or property damages in connection with this event.
6. A breach in any of the above may result in the denial of the application or revocation of an approval by the City.

Kim Martin - Barry County Chamber & CDA  
Printed Name of Applicant & Name of Organization

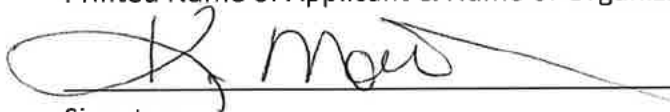
  
Signature

5/20/24  
Date

**Section 6: City Review – For Office Use Only**

**A. Police Department Review:**

Will this event require additional officers and/or equipment? If yes, please describe:

---

Other Comments:

**B. Public Services Director Review**

Will this event require the use of any of the following municipal equipment?

Trash receptacles     Barricades     Traffic cones     Restroom Cleaning

Fencing     Water or Electric     Other

Will this event require additional staff? If yes, please describe:

---

Other Comments:

**C. Fire Chief Review**

Comments:

**D. Community Development Department Review**

Comments:

Date of Meeting for Council Approval \_\_\_\_\_ Approved?  Yes  No



**BARRY COUNTY**  
MEMBER & ECONOMIC DEVELOPMENT ALLIANCE

**Barry Community Foundation**  
Recently viewed

**Barry Community Enrichment Center**

- Must have wristband to be served alcohol
- Drinks served from both sides of bar
- Floaters will be monitoring perimeter at consumption
- Beer poured into 4.5 oz tasting glass



**Music**

**Porta Johns**

**VIP Tent**

**Beer Tent**

**Food Truck**

**Food Truck**

**S Church St**

**Street Closed**

**New Center St**

**New Center St**

**New Center St**

**Summary - City of Hastings Invoices  
City Council Meeting  
May 26, 2026**

<b>No.</b>	<b>Vendor</b>	<b>Amount</b>	<b>Description (with date paid)</b>
1	Wickham Cemetery Care	\$7,787.50	Cemetery Contract and Full Burial (Apr 30, 2026)
2	Life EMS of Ionia	\$7,792.00	Contracted Ambulance Service Feb 2026 (Apr 9, 2026)
3	Life EMS of Ionia	\$7,792.00	Contracted Ambulance Service Apr 2026 (Apr 2, 2026)
4	Life EMS of Ionia	\$7,792.00	Contracted Ambulance Service May 2026 (May 5, 2026)
5	Wickham Cemetery Care	\$8,137.50	Cemetery Contract, Full Burial & Cremation (Apr 30, 2026)
6	EJ USA Inc	\$8,896.95	Three Fire Hydrants (Apr 20, 2026)
7	ETNA Supply Company	\$8,910.00	Copper Rolls for Lead Line Service (May 11, 2026)
8	Infrastructure Alternatives	\$13,882.12	Wastewater Contracted Services May 2026 (May 1, 2026)
9	Aunalytics Inc	\$15,244.28	Internet, Security and Security Apr 2026 (May 1, 2026)
10	Allied Mecanical Services	\$16,239.82	Pay Req 2 Clarifier #2 Replacement (Apr 20, 2026)
11	Advantage Plumbing & Drain	\$28,462.00	19 Lead Line Replacements Apr 2026 (Apr 30, 2026)
12	Allied Mechanical Services	\$46,831.50	Pay Req 1 Clarifier #2 Replacement (Apr 17, 2026)
13	Moore & Bruggink	\$52,847.51	Green & Market Street Improvements (May 5, 2026)
14	Kamminga & Roodvoets	\$774,668.72	Green & Market Street Improvements (May 5, 2026)
<b>14</b>	<b>Invoices</b>	<b>\$1,005,283.90</b>	



# Regular Council Agenda Item Memorandum

**To:** Mayor Tossava and City Council

**From:** Dan King

**Subject:** Thornapple Meadows (formerly North Ridge Estates) Condominiums Planned Unit Development Amendment and Final Amended Development Plan Review Public Hearing and First Reading of Ordinance # 637

**Meeting Date:** May 26, 2026

---

## Recommended Action:

Motion to approve the recommendation of the Planning Commission to amend the Thornapple Meadows (North Ridge Estates) Condominiums Planned Unit Development and Final Amended Development Plan and conduct first reading of **Ordinance 637**, amending the Thornapple Meadows Condominiums Planned Unit Development.

## Background Information:

City Council adopted Ordinance #636 on January 26, 2026, establishing the North Ridge Estates Condominiums Planned Unit Development (PUD). The permitted uses of the PUD included eight (8) 3-unit single-family condominiums, three (3) 4-unit single-family condominiums, and one (1) 2-unit single-family residential condominium with a total unit count of 38. The developers have received Planning Commission approval to modify the PUD to amend the permitted uses to eighteen (18) 2-unit single-family condominiums with a total unit count of 36.

Financial Implications: There are no direct financial implications from this request.

## Attachments:

- Public Hearing Notice
- Planning Commission Minutes from May 4, 2026
- Amended Site Plan & Landscaping Plan
- Proposed Ordinance # 637

# City of Hastings

## NOTICE OF PUBLIC HEARING NORTH RIDGE ESTATES CONDOMINIUMS PLANNED UNIT DEVELOPMENT MODIFICATION AND FINAL SITE PLAN APPROVAL

The City Council for the City of Hastings will hold a Public Hearing for the purpose of hearing written and/or oral comments from the public concerning North Ridge Estates Condominiums Planned Unit Development Modification and final amended site plan approval for property located at 1700 N. Jefferson Street Block parcel #08-55-155-000-00. City Council will review and consider final amended site plan approval for the development and construction of eighteen (18) two-unit attached residential site condominiums. The original site plan approval included three (3) four-unit, eight (8) three-unit and one (1) two-unit attached residential site condominiums. The public hearing will be held at 7:00 PM on Tuesday May 26, 2026, in the City Council Chambers on the second floor of City Hall, 201 East State Street, Hastings, Michigan 49058.



A copy of the proposed site plan and map are available for public inspection from 9:00 AM to 4:00 PM Monday through Friday at the Office of the Community Development Director, 201 East State Street, Hastings, Michigan 49058. Questions or comments can be directed to Dan King, Community Development Director, at 269.945.2468 or [dking@hastingsmi.gov](mailto:dking@hastingsmi.gov).

The City will provide necessary reasonable aids and services upon five days' notice to the City Clerk at 269.945.2468 or TDD call relay services 800.649.3777.

Linda Perin  
City Clerk



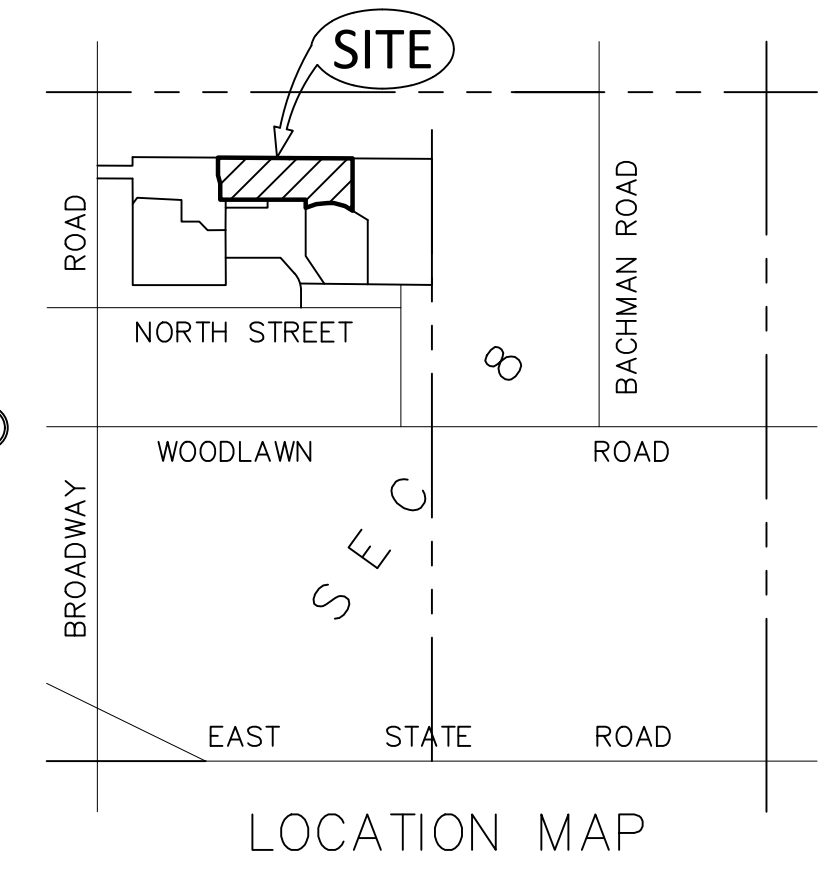
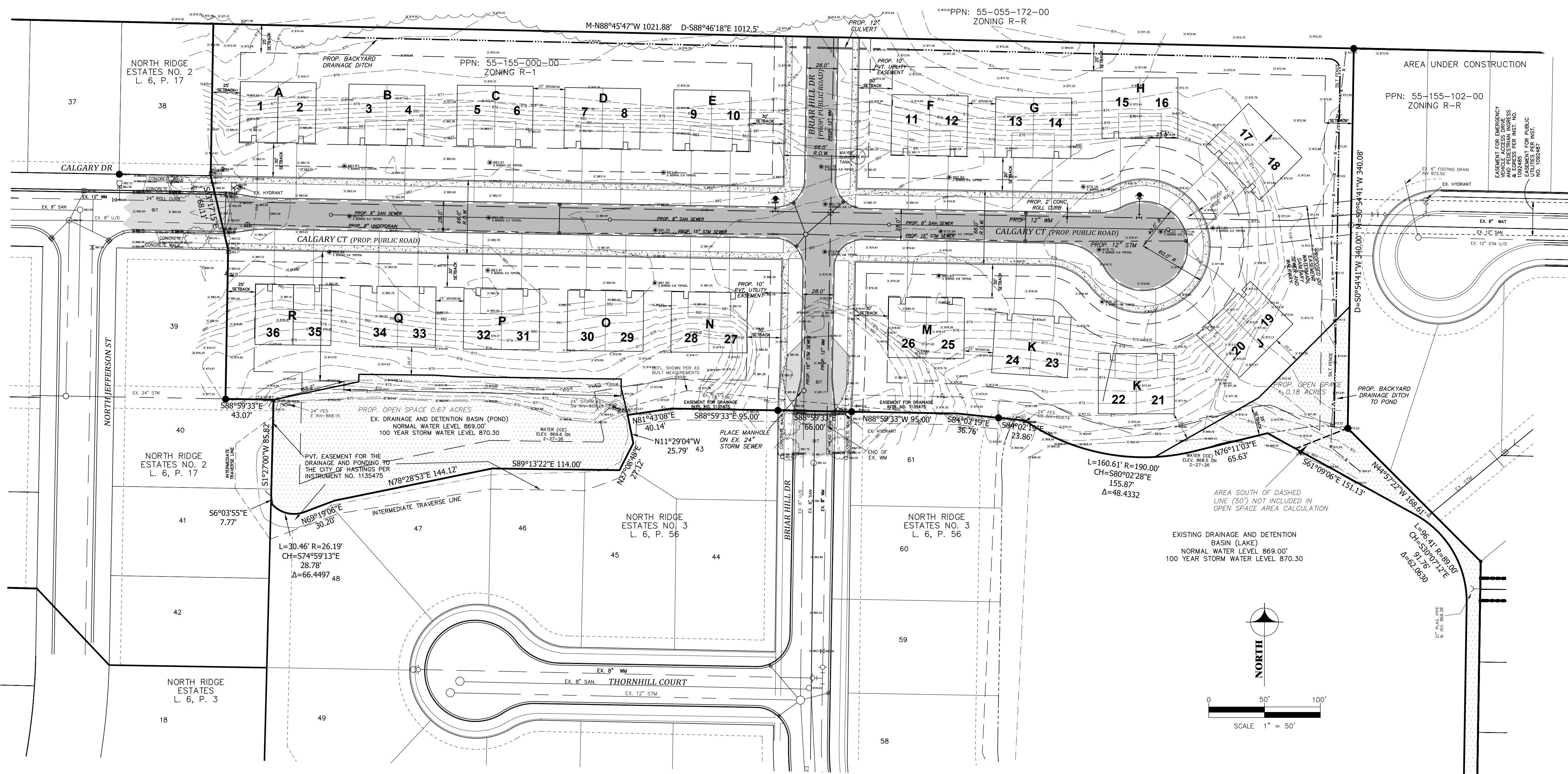

DESCRIPTION TAKEN FROM FIDELITY NATIONAL TITLE INSURANCE COMPANY COMMITMENT NO. 25-4381-RS-1 DATED AUGUST 20, 2025 AT 08:00 AM.

THE LAND IS DESCRIBED AS FOLLOWS: SITUATED IN THE CITY OF HASTINGS, COUNTY OF BARRY AND STATE OF MICHIGAN, TO-WIT: COMMENCING AT THE NORTH 1/4 POST OF SECTION 8, TOWN 3 NORTH, RANGE 8 WEST, THENCE SOUTH 0 DEGREES 54' 41" WEST 1509.27 FEET; THENCE NORTH 88 DEGREES 30' WEST 514 FEET TO THE POINT OF BEGINNING; THENCE NORTH 88 DEGREES 30' WEST 434.25 FEET; THENCE 53.93 FEET ON A LEFT CURVE WITH A RADIUS OF 354.46 FEET, CHORD BEARING NORTH 17 DEGREES 38' 29" WEST 53.88 FEET; THENCE NORTH 22 DEGREES WEST 145.9 FEET; THENCE SOUTH 63 DEGREES WEST 66 FEET; THENCE NORTH 22 DEGREES WEST 97.52 FEET; THENCE NORTH 88 DEGREES 30' WEST 480.78 FEET; THENCE NORTH 01 DEGREE 30' EAST 478.19 FEET; THENCE NORTH 88 DEGREES 59' 33" WEST 43.07 FEET; THENCE NORTH 01 DEGREE 00' 27" EAST 133.45 FEET; THENCE NORTH 13 DEGREES 17' 15" WEST 68.11 FEET; THENCE NORTH 01 DEGREE 00' 27" EAST 136.09 FEET; THENCE SOUTH 88 DEGREES 46' 18" EAST 1012.5 FEET; THENCE SOUTH 0 DEGREES 54' 41" WEST 340 FEET; THENCE SOUTH 44 DEGREES 57' 22" EAST 168.81 FEET; THENCE SOUTH 0 DEGREES 54' 41" WEST 550 FEET; TO THE POINT OF BEGINNING. EXCEPT THE PLATE OF NORTH RIDGE ESTATES NO. 3.

- NOTES:
- PROPOSED PUD ZONING
  - TOTAL GROSS ACRES: 8.45
  - THE SOUTHEAST BODY OF WATER IS APPROXIMATELY 5.4 ACRES. BECAUSE IT IS CLASSIFIED AS A LAKE (>5.0 ACRES), IT IS EXCLUDED FROM THE PROPERTY'S TOTAL GROSS ACREAGE CALCULATION.
  - MAX DWELLING DENSITY: 50 TOTAL UNITS (6 UNITS PER ACRE MAXIMUM)
  - PROPOSED UNITS: 36
  - TOTAL NET ACRES (EXCLUDING POND): 8.01
  - OPEN SPACE REQUIRED: 0.80 ACRES
  - PROPOSED OPEN SPACE: 0.85 ACRES (10.61%)

- LEGEND
- IRON FOUND
  - HYDRANT
  - ⊗ WATER VALVE
  - ⊙ WATER STOP BOX
  - ⊕ CATCH BASIN
  - MANHOLE
  - SIGN
  - ⊕ ELECTRIC MARKER
  - ⊕ GAS MARKER
  - ⊕ TELEPHONE BOX

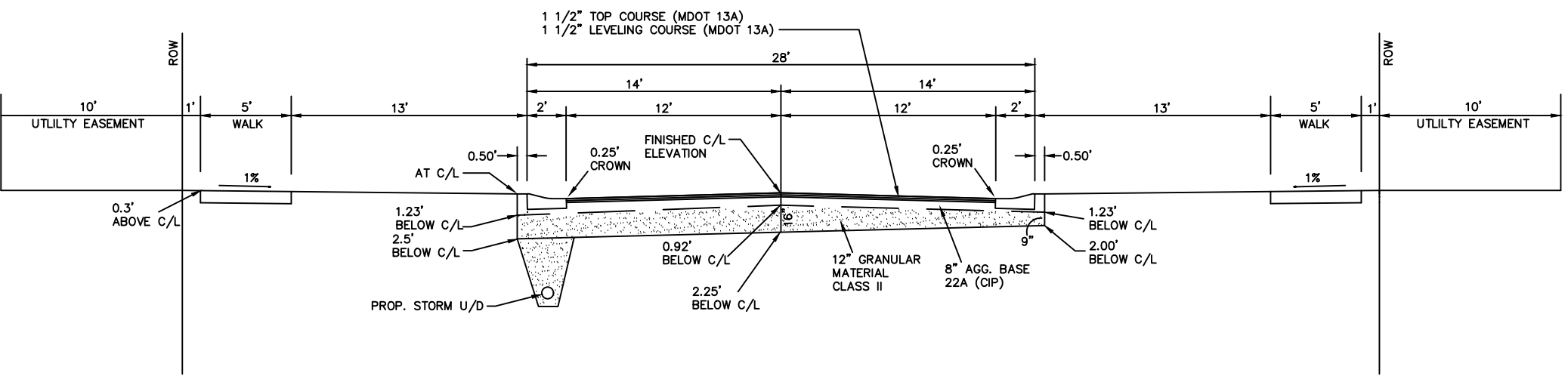

TYPICAL 28' WIDE STREET CROSS SECTION

Notes: 1 Contraction Joints shall be placed every 10 ft  
2 Expansion Joints shall be placed at 350 ft Min and at all Radius Points

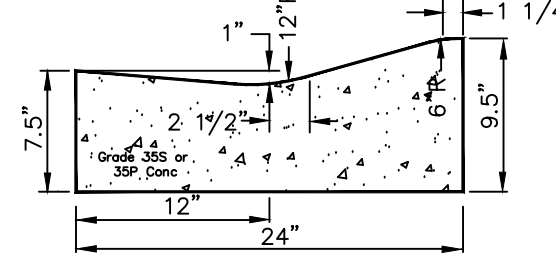

24" CONC ROLLED CURB DETAIL (PITCHED IN)

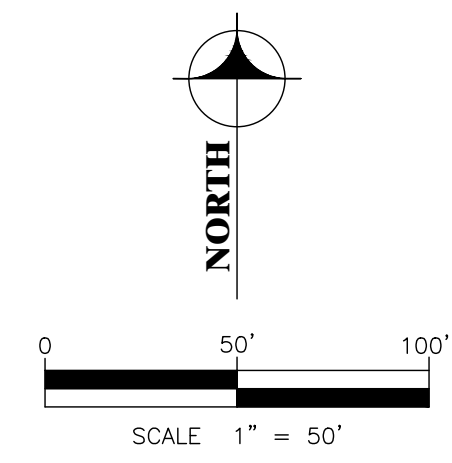

# THORNAPPLE MEADOWS CONDOMINIUMS SITE PLAN HASTINGS, MI

PREPARED FOR:  
THORNAPPLE MEADOWS HASTINGS, LLC





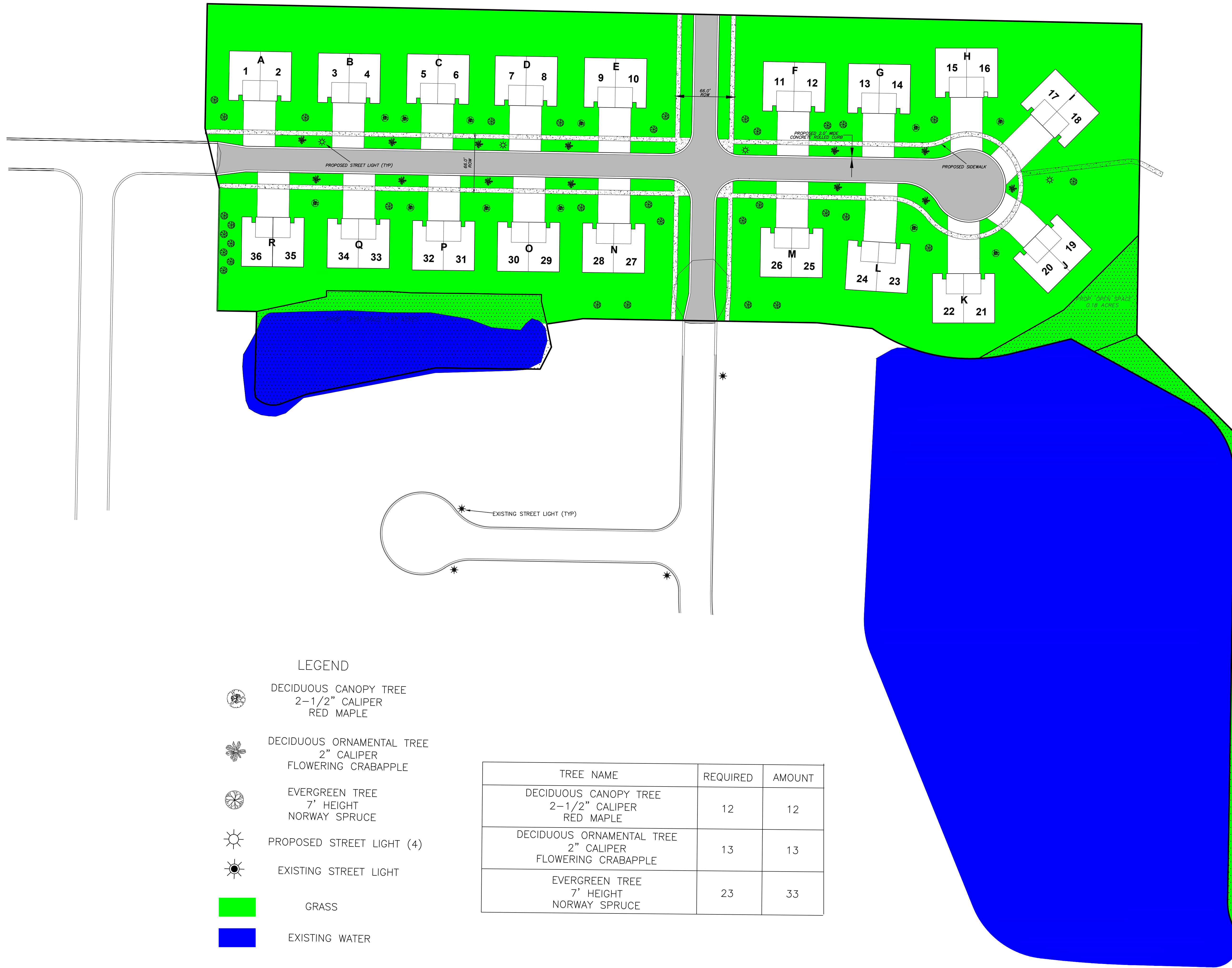

PREPARED BY:  
**Pathfinder**  
Engineering, Inc.  
2335 Byron Center Ave. S.W. Wyoming, MI 49519  
Phone 1-616-878-3885 Fax 1-616-878-4559  
DATE: 3-23-26 PROJECT NO.: 25030

COPYRIGHT © 2026 PATHFINDER ENGINEERING, INC. ALL RIGHTS RESERVED. NO PLANS MAY BE REPRODUCED OR TRANSMITTED IN ANY FORM OR BY ANY MEANS, ELECTRONIC OR MECHANICAL, INCLUDING PHOTOCOPYING, RECORDING, OR ANY INFORMATION STORAGE AND RETRIEVAL SYSTEMS, WITHOUT THE EXPRESS WRITTEN CONSENT OF PATHFINDER ENGINEERING, INC.

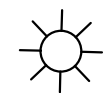

NOTES:  
 - **STREET LIGHTING:** FOUR (4) TRADITIONAL POST-TOP NON-CUTOFF FIXTURE STYLE STREET LIGHTS PROPOSED; DECORATIVE RESIDENTIAL-STYLE POLES, APPROXIMATELY 14-FOOT HEIGHT, FULL CUTOFF LED FIXTURES, APPROXIMATELY 40-60 WATT (LED EQUIVALENT).

LEGEND

-  DECIDUOUS CANOPY TREE  
2-1/2" CALIPER  
RED MAPLE
-  DECIDUOUS ORNAMENTAL TREE  
2" CALIPER  
FLOWERING CRABAPPLE
-  EVERGREEN TREE  
7' HEIGHT  
NORWAY SPRUCE
-  PROPOSED STREET LIGHT (4)
-  EXISTING STREET LIGHT
-  GRASS
-  EXISTING WATER

TREE NAME	REQUIRED	AMOUNT
DECIDUOUS CANOPY TREE 2-1/2" CALIPER RED MAPLE	12	12
DECIDUOUS ORNAMENTAL TREE 2" CALIPER FLOWERING CRABAPPLE	13	13
EVERGREEN TREE 7' HEIGHT NORWAY SPRUCE	23	33

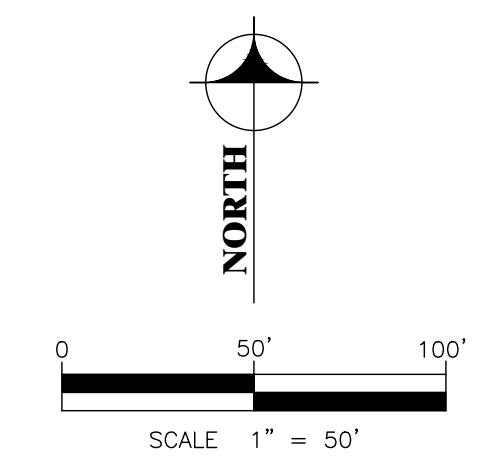

**THORNAPPLE MEADOWS  
 CONDOMINIUMS  
 LANDSCAPING PLAN**  
 HASTINGS, MI

PREPARED FOR:  
 THORNAPPLE MEADOWS HASTINGS, LLC

PREPARED BY:

**Pathfinder**  
 Engineering, Inc.

2335 Byron Center Ave. S.W. Wyoming, MI 49519  
 Phone 1-616-878-3885 Fax 1-616-878-4559  
 DATE: 11-14-25 PROJECT NO.: 25030  
 REVISED: 12-31-25  
 REVISED: 3-25-26

COPYRIGHT © 2026 PATHFINDER ENGINEERING, INC., ALL RIGHTS RESERVED. NO PLANS MAY BE REPRODUCED OR TRANSMITTED IN ANY FORM OR BY ANY MEANS, ELECTRONIC OR MECHANICAL, INCLUDING PHOTOCOPYING, RECORDING, OR ANY INFORMATION STORAGE AND RETRIEVAL SYSTEMS, WITHOUT THE EXPRESS WRITTEN CONSENT OF PATHFINDER ENGINEERING, INC.

**City of Hastings**  
COUNTY OF BARRY, STATE OF MICHIGAN

---

**ORDINANCE NO. 637**

AN ORDINANCE TO AMEND CHAPTER 90 OF THE HASTINGS CODE OF 1970, AS AMENDED, BY ~~ADDING~~ **AMENDING** THE FOLLOWING: ARTICLE 90-VII-D – NORTH RIDGE ESTATES CONDOMINIUMS PLANNED UNIT DEVELOPMENT, SECTIONS ~~90-730.19 TO 90-730.23~~ **90-730.20 (1), 90-730.21 (1), AND 90-730.22 (3)**

AMENDMENTS IN **BOLD** PRINT

**THE CITY OF HASTINGS ORDAINS:**

**SECTION I.**

Chapter 90 is hereby amended by ~~adding~~ **amending** Article 90-VII-D North Ridge Estates Condominiums Planned Unit Development, Sections ~~90-730.19 TO 90-730.23~~. **Section 90-730.20 (1), 90-730.21 (1), and 90-730.22 (3).**

**Sec 90-730.19 Amendment of Zoning Map**

The zoning ordinance of the City of Hastings is hereby amended by rezoning the following described lands from the R-1 One Family Residential District to PUD Planned Unit Development District, in accordance with the final **amended** development plan of the North Ridge Estates Condominiums Planned Unit Development, subject to all of the terms and conditions of this division:

COM N 1/4 POST SEC 8 T3N R8W, TH S0\*54'41"W 1509.27FT, TH N88\*30'W 514FT TO POB; TH N88\*30'W 434.25FT, TH 53.93FT ON LEFT CURVE RADIUS 354.46FT CHORD N17\*38'29"W 53.88FT, TH N22\*W 145.9FT, TH S68\*W 66FT, TH N22\*W 97.52FT, TH N88\*30'W 480.78FT, TH N01\*30'E 478.19FT, TH N88\*59'33"W 43.07FT, TH N01\*00'27"E 133.45FT, TH N13\*17'15"W 68.11FT, TH N01\*00'27"E 136.09FT, TH S88\*46'18"E 1012.5FT, TH S0\*54'41"W 340FT, TH S44\*57'22"E 168.81FT, TH S0\*54'41"W 550FT, TO POB. EX NORTH RIDGE ESTATES #3. 13.99 ACRES +/-.

General Location: Located along the east side of Calgary Drive and the north side of Briar Hill Drive and addressed as 1700 N. Jefferson Street Block. This parcel contains approximately 13.99 acres.

**Sec 90-730.20 Development Plan**

The rezoning of the above-described lands to the PUD Planned Unit Development District, in accordance with the final **amended** development plan of the North Ridge Estates Condominium Planned Unit Development ("the development"), is expressly subject to all the following terms and conditions:

1. Development plan. The North Ridge Estates Condominiums Planned Unit Development shall comply in all respects with the final **amended** PUD plan of the development. The final development plan has a last revision date of ~~November 12, 2025~~ **March 23, 2026**, as prepared by Pathfinder Engineering, Inc., and also includes the landscaping plan dated ~~November 14, 2025~~ **March 25, 2026**, the application for planned unit development rezoning; the October 16, 2025, project summary narrative; and all other materials submitted with the application, except to the extent that any such materials may be inconsistent with this ordinance.
2. The final PUD plan of the development includes the conditionally approved preliminary site condominium plan.

**Sec 90-730.21 Permitted Uses**

1. The North Ridge Estates Condominiums PUD is approved for use as ~~(8) 3-unit single family residential condominiums, (3) 4-unit single family residential condominiums, and (1) 18-~~ 2-unit single family residential condominium with a total unit count of ~~38~~ **36**.

**Sec 90-730.22 Development Requirements**

1. Setbacks will conform to R-2 Single Family Residential District standards.
2. Unit sizes will range from 1,100 to 2,000 square feet.
3. Building width will ~~range from 68 feet to 136 feet~~ **68 feet**.
4. Calgary Drive will be extended from the west and Briar Hill Drive will be extended from the south and will be subject to city public road construction standards. Sidewalks will be constructed on both sides of the Calgary and Briar Hill public road extensions subject to city sidewalk construction standards.
5. The stormwater management plan and utility system (sewer/water) proposal shall be subject to City review/approval, per the approval of the Planning Commission on December 1, 2025.
6. The location, description, use/occupancy and maintenance provisions for all general and limited common elements shall be provided in the master deed for the project and shall be subject to City review/approval.
7. The development will adhere to the 10% Open Space minimum requirement.

**Sec 90-730.23 Findings**

The city council hereby determines that the development complies with the provisions of the city zoning ordinance and promotes its intent and purpose. The council further finds that the development, upon construction and use in full compliance with all of the terms and provisions of this division and the city zoning ordinance, will be compatible with city master plan, adjacent uses of lands, the natural environment and the capacities of public services and facilities affected by the department. the city council further determines that the development will not

have unreasonable economic impact on adjacent lands and will not change the essential character of the area.

SECTION II.

If any article, section, subsection, sentence, clause, phrase, or portion of this ordinance is, for any reason, held invalid or unconstitutional by any court of competent jurisdiction, such portion shall be deemed a separate, distinct, and independent provision, and such holding shall not affect the validity of the remaining portions of this ordinance.

SECTION III.

This ordinance shall become effective upon its adoption and publication as provided by City Charter.

Moved by , with support by , that Ordinance No. **XXX** be adopted as read.

YEAS:  
NAYS:  
ABSENT:

Adoption Date:  
Effective Date:  
First Reading:  
Second Reading:

CITY OF HASTINGS

\_\_\_\_\_  
By: Linda Perin  
Hastings City Clerk

CERTIFICATE

The undersigned, being the duly qualified and acting Clerk of the City of Hastings, Michigan, does hereby certify that the foregoing is a true and complete copy of an Ordinance adopted by the City Council of the City of Hastings, at a regular meeting of the City Council on the th day of 2026, at which meeting a quorum was present and remained throughout, and that the original of said Ordinance is on file in the records of the City of Hastings. I further certify that the meeting was conducted, and public notice was given pursuant to and in compliance with Act No. 267, Public Acts of Michigan of 1976, as amended, and that minutes were kept and will be or have been made available as required thereby.

Dated:

\_\_\_\_\_  
Linda Perin  
City Clerk



# Regular Council Agenda Item Memorandum

**To:** Mayor Tossava and City Council

**From:** Dan King

**Subject:** Parkinson's Pitch Event & Resolution 2026-10

**Meeting Date:** May 26, 2026

---

## Recommended Action:

Motion to approve, under direction of staff, the request from Douglas Logan representing Parkinson's Pitch to hold a bean bag toss tournament on the soccer field in Fish Hatchery Park on **Saturday, August 1, 2026, from 10:00 AM to 6:00 PM**, and to adopt **Resolution 2026-10** staying the necessary ordinances to conduct the event.

## Background Information:

Parkinson's Pitch is a third-party fundraiser for the Michigan Parkinson Foundation (MPF). MPF was founded in 1983 by a Detroit area physician and caregiver to provide patients and their caretakers throughout the State of Michigan with education about the disease, providing exercise classes, and other support services. All proceeds raised during the event will stay in Michigan.

## Financial Implications:

None

## Attachments:

- Request Letter
- Special Event Application
- Resolution 2026-10

Members of City Council  
City of Hastings  
201 E State St  
Hastings, MI 49058

Subject: Use of Fish Hatchery Park in Hastings.

Dear members of the City Council of Hastings,

Parkinson's Pitch is a third-party fundraiser for Michigan Parkinson Foundation (MPF). We would like to hold a Cornhole tournament for MPF on the soccer field in Fish Hatchery Park. The tournament will be a double elimination with a cash prize for the top four two person teams and will be held on Aug 1, 2025. We would like to request the following:

- 1.To reserve the soccer field for the days of July 31, 2026, for setup and Aug 1, 2026, until dark, for the event and clean up.
2. To allow the section of the parking lot near the soccer field to have enough room for up to 4 concession trailers or food trucks.
- 3.To erect portable gazebos near the bleachers.
- 4.Permission to use spray paint on the soccer field to mark the lanes.
- 5.Permission to distribute materials pertaining to Parkinson's Disease.

If all goes well with this tournament, I hope to make it a yearly event. The MPF helps Parkinson's patients and their caretakers throughout the state with education about the disease, provides exercise classes, and support with more than 70 support groups throughout the state. All of the proceeds from this and other fundraisers remain within the state of Michigan.

Respectfully,

Douglas L Logan

Parkinson's Pitch - a third-party fundraiser for the Michigan Parkinson Foundation  
1096 Cook Rd  
Hastings, MI 49058

Email address: [REDACTED]

Phone: [REDACTED]



## City of Hastings Special Event Application

The City of Hastings values the unique events and gatherings that make our community special. The City has created this application form to help organizations provide adequate information for their requests to be considered. Please contact the Community Development Department with any questions or concerns about this form.

### Section 1: Applicant/Organization Information

<input type="text" value="Douglas L Logan"/>	<input type="text"/>		
Applicant/Organization Name	Phone		
<input type="text" value="Douglas L Logan"/>	<input type="text"/>	<input type="text"/>	
Contact Name	Phone	Email	
<input type="text" value="1096 Cook Rd"/>	<input type="text" value="Hastings"/>	<input type="text" value="MI"/>	<input type="text" value="49058"/>
Street	City	State	Zip

<input type="text"/>	<input type="text"/>
Contact person on day of event (if different than above)	Phone

### Section 2: Event Information

<input type="text" value="Parkinson's Pitch - A Corn Hole Tournament"/>	
Name of Event	
<input type="text" value="A single elimination Corn Hole Tournament"/>	
Description of Event	
<input type="text" value="August 1, 2026"/>	<input type="text" value="10:00 a.m. - 6:00 p.m."/>
Event Dates	Time (From/To)
<input type="text" value="July 31, 2026 12:00 p.m. - 6:00 p.m."/>	<input type="text" value="August 1, 2026 6-8p.m."/>
Set up Date(s) and Time(s)	Clean Up Date(s) and Time(s)

Fish Hatchery Park, Hastings Michigan

Location(s) of Event

18

100+

Estimated number of volunteers

Estimated daily attendance (if known)

**Section 3: Event Details**

Please indicate if any of the following will be a part of your event area:

- Road closure
  - o If checked, please provide a proposed detour route.
- Closure of public parking area
- Use of park area
- Firepits/open flame
- Fireworks or pyrotechnics
  - o If yes, provide a copy of liability insurance listing the City as an additional insured party.
- Food and/or non-alcoholic beverage service or sales (if yes, contact Barry County Health Department)
  - o If yes, provide copy of Health Department Food Service License
- Temporary structures (including tents or pavilions)
- Music
  - o If yes, what time will music begin and end? \_\_\_\_\_
  - o If yes, what type of music is proposed? Live – Acoustic Live - Amplification Recorded
  - o Loudspeakers or public address system \_\_\_\_\_
- Parade
- Race (ex: 5K)
- Vendors/sale of goods
- Carnival rides
  - o If yes, provide a copy of liability insurance listing the City as an additional insured party.
- Signs or banners
- Animals/petting zoo
- Portable restroom facilities
- Donation collection/free will offering
- Other \_\_\_\_\_
- Alcohol
  - o If yes, provide copy of liquor liability insurance with the City listed as an additional insured.
  - o If yes, provide a copy of Michigan Liquor Control License Application.
  - o If yes, describe measures to be taken to prohibit the sale of alcohol to minors (use separate pages if necessary).
  - o If the alcohol is being served in the Social District, a Council Resolution suspending the district is required.

If possible I'd like to have WBCH do a remote broadcast during the tournament. I understand that there will be other events going on at the time so only if it does not bother them.

Please describe how garbage will be managed?

In addition to the trash receptacles that are in the park I will bring two additional 55 gal trash bins to set up near the soccerfield for the collection of trash. After the event the volunteers who helped run the fundraiser will help be sure all trash is collected.

#### Section 4: Site & Event Plan

Please prepare a site plan that includes the following information:

Location of all temporary structures, food/concessions, booths, portable restrooms, road closures, barricades, music, event signage, garbage cans, and other event locations. Include location of exit pathways.

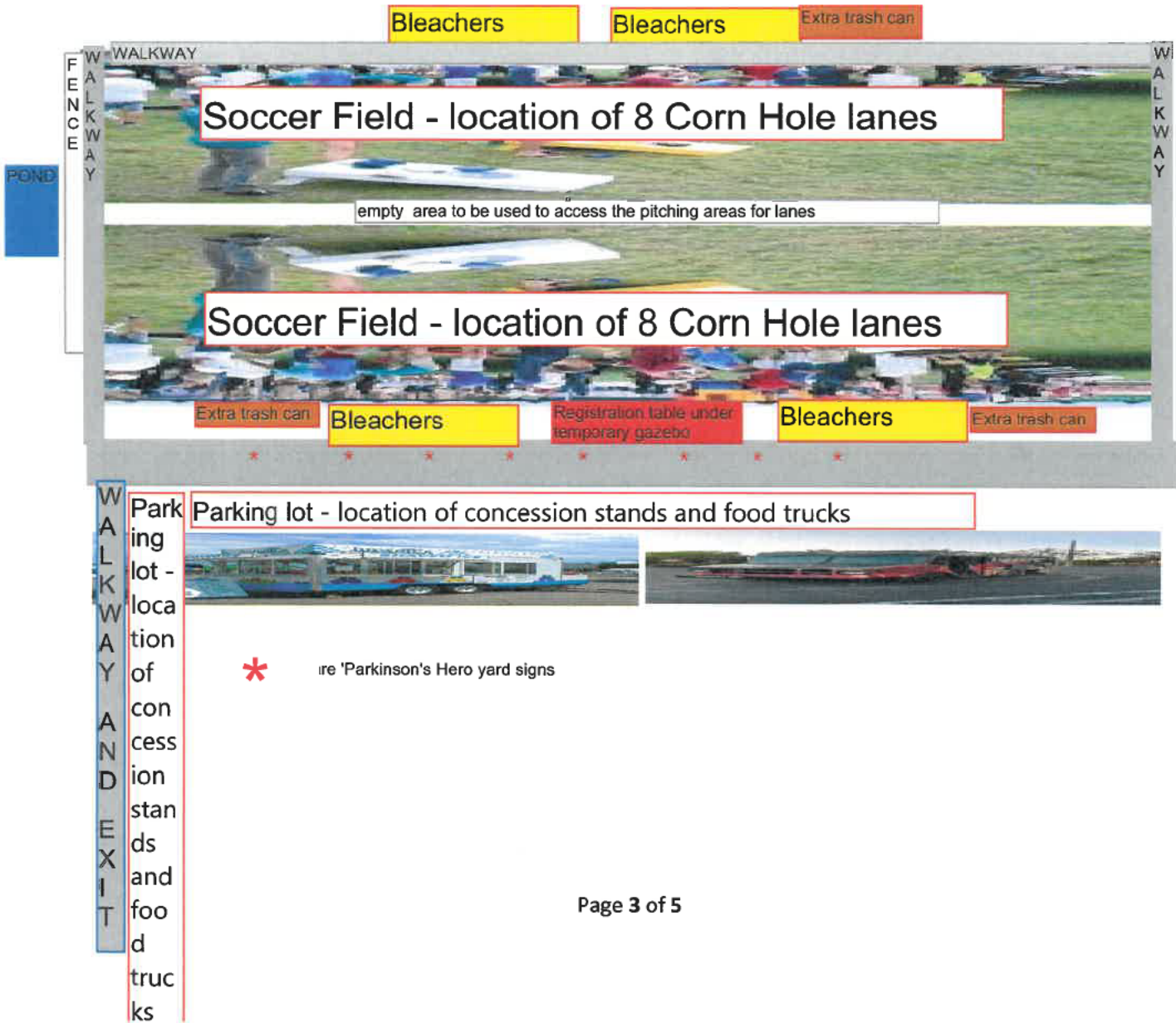

**Section 5: Acknowledgements and Hold Harmless Agreement**

The Applicant understands and agrees to the following:

1. This application is subject to review by various city departments and must be approved by the City Council. Failure to submit this application in a timely manner may delay approval or result in the denial of the application. Submission of the application does not guarantee an approval. The City may require conditions on the approval of any application.
2. The applicant must comply with all local and applicable state laws and policies. The Applicant acknowledges that approval of the special event does not relieve the applicant from meeting any requirements of law or those of other bodies or agencies applicable to the event.
3. The Applicant agrees to clean up and restore the area in the condition it was found prior to the event. The City is not responsible for equipment or personal items left on public property.
4. The Applicant acknowledges that they shall not discriminate against any employee or applicant for employment because race, color, religion, sex, national origin, age, disability, or any other applicable status protected by federal, state, or local law. The Applicant further agrees that it will comply with the Civil Rights Act of 1973, as amended, and the Michigan Civil Rights Act of 1976 (78. Stat 252 and 1976 PA 453) and will require the same of any consultant or sub-contractor involved in hosting the event.
5. Upon approval of the event, the Applicant agrees to fully defend, indemnify and hold harmless the City, its City Council, its officers, employees, agents, volunteers, and contractors from any and all claims, demands, losses, obligations, costs, expenses, verdicts, and settlements (including but not limited to attorney fees and interest) resulting from any act or omission by the applicant, its agents, employees, contractors, and volunteers, and violation of state or federal law, and any other acts of the applicant or attendees causing personal injury or property damages in connection with this event.
6. A breach in any of the above may result in the denial of the application or revocation of an approval by the City.

Douglas L Logan

Michigan Parkinson's Foundation

---

Printed Name of Applicant & Name of Organization

*Douglas L. Logan*

05/02/2026

---

Signature

Date

**Section 6: City Review – For Office Use Only**

**A. Police Department Review:**

Will this event require additional officers and/or equipment? If yes, please describe:

---

Other Comments:

**B. Public Services Director Review**

Will this event require the use of any of the following municipal equipment?

Trash receptacles     Barricades     Traffic cones     Restroom Cleaning  
 Fencing     Water or Electric     Other

Will this event require additional staff? If yes, please describe:

---

Other Comments:

**C. Fire Chief Review**

Comments:

**D. Community Development Department Review**

Comments:

Date of Meeting for Council Approval \_\_\_\_\_ Approved?  Yes  No

**City Of Hastings**  
COUNTY OF BARRY, STATE OF MICHIGAN

---

**RESOLUTION 2026-10**

**TO STAY THE NECESSARY ORDINANCES TO HOLD PARKINSON’S PITCH EVENT IN FISH HATCHERY PARK ON SATURDAY AUGUST 1, 2026, FROM 10:00 AM TO 6:00 PM**

WHEREAS, Douglas Logan representing Parkinson’s Pitch, by way of correspondence, has requested the use of the soccer field in Fish Hatchery Park, for the purpose of holding a bean bag toss tournament to raise funds for Michigan Parkinson Foundation on August 1, 2026, from 10:00 am to 6:00 pm; and

WHEREAS, the City Council of the City of Hastings at its regular meeting on May 26, 2026, approved the location of Fish Hatchery Park on August 1, 2026, from 10:00 am to 6:00 pm; and

WHEREAS, Douglas Logan desires to ensure the Parkinson’s Pitch event is conducted in good taste and in accordance with all laws and regulations, now

THEREFORE, BE IT RESOLVED that the City of Hastings hereby stays for August 1, 2026, from 10:00 am to 6:00 pm under Section 2-34 of the Hastings City Code, the following Ordinances:

Section 6-1  
58-35 (d) and Section 58-38 (a), (g), and (h)

A motion to adopt the foregoing resolution being offered by Member, with support by Member:

YEAS:  
NAYS:  
ABSENT:

MOTION DECLARED ADOPTED

I hereby certify that the foregoing resolution was adopted at a duly held and attended regular meeting the 26<sup>th</sup> day of May 2026, by the City Council of the City of Hastings, by a vote of members voting in favor thereof, members voting against, and member(s) absent.

---

Linda Perin  
City Clerk

### **Sec 58-35 Park Property**

No person in any park shall:

- (a) Willfully mark, deface, disfigure, injure, displace or remove any building, table, bench, fireplace, railings, pavement, water lines, or other public utilities or appurtenances.
- (b) Fail to cooperate in maintaining restrooms or washrooms in a neat and sanitary condition, nor shall any person over the age of six years use the restroom facilities of the opposite sex.
- (c) Dig or remove soil, rocks, stones, trees, shrubs, or plants, nor pick flowers, nor attach any rope, wire or other device to any tree, plant or any structure.
- (d) Construct or erect any building or structure of any kind, either permanent or temporary, nor run public services into park lands, except on special written permit issued by the director.
- (e) Climb any tree; or walk, stand or sit upon any monument, vases, fountains, railings, or fences, nor upon any other property not designated or customarily used for such purposes.

### **Sec 58-38 Prohibited Acts**

- (a) No parades, drills, exhibitions, meetings, concerts, speeches, lectures or public entertainment shall be held in any park except with permission of the council.
- (b) Fires are prohibited except in fireplaces or stoves provided for such purposes, and such fires shall be extinguished after such use.
- (c) During the nighttime, no person shall sleep whether in a vehicle, trailer, tent, hammock, other manner in a park, public way or other public place.
- (d) No person shall hunt, trap, pursue any wildlife at any time, in any manner, shape or form, nor use any weapon of any description nor any kind of trapping device.
- (e) No person shall play baseball, football, hockey, roller skate or ice skate, or engage in any other violent or rough exercise or play in any park except in such areas designated for such use.
- (f) No adult person shall in any manner use any of the playground apparatus or devices meant exclusively for the use of children.
- (g) No person shall advertise any placard or advertisement of any kind in the park, nor shall any person distribute in any manner, nor place any handbill, pamphlet, circular, etc., nor post, stencil or otherwise affix any notice or bills, advertisement or other papers upon any structure or thing in or about the park.
- (h) No person shall carry on any trade or business or sell or display any goods, wares or merchandise in any park or conduct any commercial enterprise thereon (per the

deed restriction for Tyden Park); however, nonprofit organizations generally recognized as operating in the community by the city council may hold or formally sponsor events and fundraising activities at city parks upon permit of the council.



# Regular Council Agenda Item Memorandum

**To: City Council**

**From: Robert Neil Street, Superintendent**

**Subject: Dust Control**

**Meeting Date: Tuesday, May 26, 2026**

---

Recommended Action:

Motion to approve the application of dust control on city gravel streets by Leaping Lizards in the amount of **\$6,100**.

Background Information:

This application will cover the 14,200 ft gravel roads within the City limits. This company has provided dust control in the past.

Financial Implications:

This is a budgeted item and still has sufficient funds.

Attachments:

- Leaping Lizards
- Liquid solutions-no return phone call

Leaping Lizards  
P.O. Box 223  
Hastings, MI 49058

# Estimate



**ADDRESS**  
City Of Hastings  
201 East State Street  
Hastings, Mi 49058

**SHIP TO**  
City Of Hastings  
201 East State Street  
Hastings, Mi 49058

ESTIMATE #	DATE	EXPIRATION DATE
3050	05/11/2026	05/30/2026

DATE	ACTIVITY	DESCRIPTION	QTY	RATE	AMOUNT
	<b>Services</b>	Grade and spray 14200ft of city roadway	1	6,100.00	6,100.00

TOTAL

**\$6,100.00**

Accepted By

Accepted Date

## Hastings City Police



201 E. State St.  
Hastings, MI 49058  
(269) 948-4800 Dispatch  
(269) 945-5744 Office  
(269) 945-4358 Fax



Dale Boulter  
Chief of Police

Julissa Kelly  
Deputy Chief

### Hastings Police Department Council report for the month of April 2026

#### Staffing

Staffing has remained unchanged since my last report. One officer has returned from light duty and resumed duties on the schedule. The Detective Sergeant position continues to be beneficial with several complaints being handled from this office.

One interview was conducted with a certified officer that withdrew from the process. We are currently recruiting certified officers and speaking with them one on one.

#### Statistics

Calls for Service: 433

Arrests: 21

Traffic Accidents: 21

Non-Traffic Accidents: 5

Citations: 29 (17 moving, 12 non-moving)

Traffic Stops: 108

#### Reserve Officers

The Reserve Department contributed 48.5 hours for April.

## Training

Officers continue to train with the Taser 10 along with conducting Virtual Reality Training with the system. We are currently waiting for the Taser 10 holsters to arrive as they were back ordered. We are utilizing this time to continue to train on the new platform.

DC Kelly continues with her Command level 1 training attending class in Grayling for two days per month. Her last session of the training will be June 8<sup>th</sup> and 9<sup>th</sup>.

DC Kelly and I attended the Domestic Terrorism and Violent Extremism conference last month held at the Crystal Mountain Resort. I have worked with our Barry County Emergency Manager to fund this training.

Sgt. Pickett attended Red Dot Instructor course and is now certified to instruct our officers with the new weapon platform.

## PD Renovation

Construction has begun in the PD with all demolition complete. The new walls have been framed and soon to have electricians on site. The project is on point and somewhat ahead of schedule. It is exciting to see the work being performed and the transition taking place inside the office.

## Code Compliance report

Attached

Respectfully submitted,

Dale Boulter

Chief of Police

**HASTINGS CITY COUNCIL  
MONTHLY REPORT  
MONTH OF April 2026**

**From Hastings Police Department**

**Chief Dale Boulter**

**Total Complaints: 433**

**Total Arrests: 21**

**Adults 9 Improper plate-1, A&B-3, B&E of Res.-1, Trespass-1, Sex Offense-1, OWI Alc.-1, No Ops-1.**

**Juveniles: 0**

**Arrests Warrants for Other Departments: 12 Obstructing Justice-12.**

**Traffic Summary:**

**Traffic Accidents: 21**

**Property Damage: 9 Injuries: 12 Fatal: 0 Non-Traffic: 5.**

**Tickets Issued: 29**

**Moving Violations Issued: 17**

**Non-Moving Violations: 12**

**POLICE VEHICLES**

TOTAL MILES: 7,946

TOTAL GALLONS OF FUEL USED: 660.2

<u>VEHICLE</u>	<u>MILAGE</u>	<u>VEHICLE</u>	<u>MILAGE</u>
<u>41/2020 FORD</u>	<u>77,929</u>	<u>45/2018 FORD</u>	<u>53,217</u>
<u>42/2021 FORD</u>	<u>82,320</u>	<u>46/2022 FORD</u>	<u>11,289</u>
<u>43/2023 FORD</u>	<u>28,642</u>	<u>47/2023 FORD</u>	<u>32,680</u>
<u>44/2025 FORD</u>	<u>9,818</u>	<u>48/2016 FORD</u>	<u>95,940</u>

**ADDITIONAL INFORMATION:**

The Hastings Police Reserve officers worked a total of 48.5 hours for the month.

<u>CLASSIFICATION</u>	<u>CURRENT MONTH</u>	<u>PREVIOUS YEAR</u>	<u>YTD CURRENT</u>	<u>YTD PREVIOUS</u>	<u>YTD COMPARED</u>
FATAL ACCIDENTS	0	0	0	0	0
INJURY ACCIDENTS	12	5	24	9	+15
P D ACCIDENTS	9	11	38	43	-5
NON-TRAFFIC	5	5	17	20	-3
SPEEDING	4	12	18	34	-16
OTHER HAZARDOUS	13	13	44	36	+8
NON-HAZARDOUS	12	11	41	45	-4
PARKING	11	1	148	173	-25
<u>TOTAL</u>	60	58	330	360	-30

City of Hastings  
Code Compliance Officer  
March 2026 Activity Report



QUANTITY	COMPLAINT
1	Animal related (90-835)
0	Grass and weeds more than 8" tall (38-105)
10	Compostable yard debris and refuse in right-of-way, snow piles (74-39, 74-71, 74-72)
5	Garbage Code Violations (66-88/89/90/93/94)
31	Vehicles parked on unapproved surfaces – residential zones (90-929)
17	Unlicensed/Inoperable vehicles, parts, or tire storage (38-76, 77, 78)
22	Refuse and debris in unscreened area of yard (90-881, 90-882)
3	Rental Property Issues & Complaints
10	Signage issues/ Signs in Right-Of-Way
7	Fencing Issues
3	Fence Permits Issued
4	Structure & Building Maintenance Issues
0	Recreational Vehicle Issues
0	Abandoned refrigerator w/door attached (54-61)
8	Sidewalk parking/right-of-way obstructions (74-71)
25	Miscellaneous Issues & Complaints
<b>146</b>	<b>Total Violations/Complaints Handled</b>
30	Letters sent
2	Citations issued
156	Follow Ups
<b>NOTES:</b>	<b>Miscellaneous Issues/ Complaints details</b>



Investments & Deposits Status Report as of April 30, 2026

Institution	Account Description	Balance	Interest Rate
<b>Flagstar</b>	Common Cash (Primary Checking)	\$ 2,871,383.11	0.45%
	Payroll	\$ 1,855.25	0.45%
	Savings	\$ 905,268.95	2.63%
	**Tax Collection	\$ 2,917.32	N/A
	<b>Total</b>	<b>\$ 3,781,424.63</b>	
<i>** Includes funds collected on behalf of other governmental agencies</i>			
<b>Highpoint</b>	Common Cash	\$ 40,760.17	N/A
	Ambulance Billing	\$ 1,772.75	N/A
	Drug Enforcement	\$ 18,211.94	N/A
	*Tax Collection	\$ -	N/A
	<b>Total</b>	<b>\$ 60,744.86</b>	
<i>* Includes funds collected on behalf of other governmental agencies</i>			
<b>Michigan CLASS</b>	General Fund (Pooled)	\$ 6,835,915.10	3.7478%
	Sewer Fund	\$ 397,116.50	3.7478%
	Water Fund	\$ 231,033.61	3.7478%
	Equipment Fund	\$ 319,044.07	3.7478%
	<b>Total</b>	<b>\$ 7,783,109.28</b>	
<b>American Dep Mgmt Co</b>	Money Market Account	\$ 4,126,695.98	3.47%
<b>Huntington Bank</b>	Brokerage Account-Fire Department	\$ 827,443.38	N/A
	<i>Sage Trust Beneficiary Distribution</i>		
<b>Total, All Investments &amp; Deposits</b>		<b>\$ 16,579,418.13</b>	

Institution	Balance	% of Total
Flagstar	\$ 3,781,424.63	22.8%
Highpoint	\$ 60,744.86	0.4%
Michigan CLASS	\$ 7,783,109.28	46.9%
American Dep Mgmt Co	\$ 4,126,695.98	24.9%
Huntington Bank	\$ 827,443.38	5.0%
<b>Total</b>	<b>\$ 16,579,418.13</b>	<b>100.0%</b>

Type of Investment or Deposit	Balance	% of Total
Interest	\$ 16,515,755.95	99.6%
Non-Interest	\$ 63,662.18	0.4%
<b>Total</b>	<b>\$ 16,579,418.13</b>	<b>100.00%</b>

# CITY OF HASTINGS

## SUMMARY REVENUES AND EXPENDITURES COMPARED TO BUDGET FOR THE 10 MONTHS ENDING APRIL 30, 2026

THIS YEAR FISCAL YTD 30-APR-26	REVISED BUDGET 2025-2026	FISCAL YTD % OF BUDGET	LAST YEAR FISCAL YTD 30-APR-25	REVISED BUDGET 2024-2025	FISCAL YTD % OF BUDGET
--------------------------------------	--------------------------------	------------------------------	--------------------------------------	--------------------------------	------------------------------

### FUND 101 - GENERAL FUND

#### REVENUE

TAXES	3,811,290.59	3,746,294	102.00%	3,623,966.98	3,638,300	100.00%
SPECIAL ASSESSMENTS	43,037.96	43,650	99.00%	43,221.00	32,500	133.00%
LICENSES & PERMITS	11,672.13	17,775	66.00%	22,260.82	19,250	116.00%
FEDERAL REVENUES	.00	0	0.00%	.00	236,216	0.00%
STATE SHARED REVENUES	815,729.28	1,153,016	71.00%	1,048,428.76	1,139,391	92.00%
INTERGOVERNMENTAL REVENUES	601,313.15	570,000	105.00%	1,173,809.45	923,228	127.00%
CHARGES FOR SERVICES	550,774.78	646,150	85.00%	44,646.16	668,100	7.00%
FINES & FORFEITURES	14,229.67	10,000	142.00%	12,775.94	8,500	150.00%
INTEREST AND RENTALS	1,006,759.32	430,840	234.00%	337,597.32	335,400	101.00%
OTHER REVENUE	984,986.99	73,500	1340.00%	156,124.68	451,300	35.00%
INCOMING TRANSFERS	.00	0	0.00%	.00	0	0.00%
<b>TOTAL REVENUE &amp; INCOMING TRANSFERS</b>	<b>7,839,793.87</b>	<b>6,691,225</b>	<b>117.00%</b>	<b>6,462,831.11</b>	<b>7,452,185</b>	<b>87.00%</b>

#### EXPENDITURES

CITY COUNCIL	52,880.43	77,525	68.00%	61,555.55	82,326	75.00%
MAYOR	10,799.84	16,445	66.00%	12,169.56	14,811	82.00%
CITY MANAGER	205,551.74	265,750	77.00%	162,070.20	192,810	84.00%
FINANCE DEPARTMENT	361,174.98	446,096	81.00%	300,370.39	396,945	76.00%
CLERK	94,616.48	121,552	78.00%	97,890.11	117,396	83.00%
INFORMATION TECHNOLOGY	209,046.59	271,100	77.00%	205,567.97	244,000	84.00%
BOARD OF REVIEW	2,120.27	2,612	81.00%	2,769.02	2,512	110.00%
TREASURER	90,025.75	95,730	94.00%	64,428.32	83,928	77.00%
ASSESSOR	143,026.57	197,742	72.00%	123,127.92	171,282	72.00%
ELECTIONS	41,176.01	57,681	71.00%	31,369.95	56,368	56.00%
CITY HALL & GROUNDS	354,163.55	523,500	68.00%	102,130.49	158,950	64.00%
LEGAL AND AUDIT	52,113.00	73,500	71.00%	51,439.00	70,000	73.00%
OTHER GENERAL GOVERNMENT	558,116.54	568,147	98.00%	833,809.85	588,415	142.00%
POLICE	1,576,600.06	2,327,377	68.00%	1,540,305.17	2,099,689	73.00%
CODE COMPLIANCE	30,623.22	55,660	55.00%	36,757.81	50,962	72.00%
FIRE DEPARTMENT	632,912.10	662,032	96.00%	388,385.70	524,545	74.00%
INSPECTIONS	32,579.00	65,000	50.00%	52,441.00	100,000	52.00%
DEPT OF PUBLIC SERVICE ADMIN	59,879.48	60,082	100.00%	113,078.25	159,240	71.00%
PARKING LOTS - NON SAD	7,156.18	21,000	34.00%	7,637.43	23,000	33.00%
PARKING LOTS - SAD	18,389.09	31,460	58.00%	252,079.46	267,500	94.00%
STREET LIGHTING	82,778.64	118,000	70.00%	92,948.96	99,500	93.00%
COMMUNITY SERVICES	393,658.85	406,328	97.00%	206,960.89	300,355	69.00%
BROWNFIELD GRANT	.00	0	0.00%	.00	0	0.00%
PLANNING AND ZONING	7,049.47	16,636	42.00%	8,159.04	18,685	44.00%
JOINT PLANNING & ZONING	1,719.43	1,350	127.00%	37.50	400	9.00%
COMMUNITY & ECONOMIC DEVELOPMNT	128,186.65	160,957	80.00%	122,542.94	143,143	86.00%

# CITY OF HASTINGS

## SUMMARY REVENUES AND EXPENDITURES COMPARED TO BUDGET FOR THE 10 MONTHS ENDING APRIL 30, 2026

THIS YEAR FISCAL YTD YTD ACTUAL	REVISED BUDGET BUDGET	FISCAL YTD % OF BUDGET	LAST YEAR FISCAL YTD 30-APR-25	REVISED BUDGET BUDGET	FISCAL YTD % OF BUDGET
---------------------------------------	-----------------------------	------------------------------	--------------------------------------	-----------------------------	------------------------------

### *FUND 101 - GENERAL FUND*

COMMUNITY DEVELOPMENT GRANTS	.00	100	0.00%	61,536.50	65,100	95.00%
CABLE ACCESS	8,486.13	12,422	68.00%	10,706.31	13,776	78.00%
PARKS AND RECREATION	393,532.40	542,581	73.00%	241,764.00	1,344,325	18.00%
ARTS AND CULTURAL ACTIVITIES	45,571.13	41,840	109.00%	70,118.39	81,526	86.00%
OTHER FINANCING USES	281,624.00	281,624	100.00%	549,696.00	549,696	100.00%
<hr/>						
TOTAL EXPENDITURES & OUTGOING TRANSFERS	5,875,557.58	7,521,829	78.00%	5,803,853.68	8,021,185	72.00%
<hr/>						
NET REVENUE OVER EXPENDITURES	1,964,236.29	( 830,604)		658,977.43	( 569,000)	
<hr/>						

# CITY OF HASTINGS

## SUMMARY REVENUES AND EXPENDITURES COMPARED TO BUDGET FOR THE 10 MONTHS ENDING APRIL 30, 2026

	THIS YEAR FISCAL YTD 30-APR-26	REVISED BUDGET 2025-2026	FISCAL YTD % OF BUDGET	LAST YEAR FISCAL YTD 30-APR-25	REVISED BUDGET 2024-2025	FISCAL YTD % OF BUDGET
--	--------------------------------------	--------------------------------	------------------------------	--------------------------------------	--------------------------------	------------------------------

### **FUND 202 - MAJOR STREETS**

REVENUES	673,019.17	841,849	80.00%	703,190.16	1,235,556	57.00%
INCOMING TRANSFERS	.00	0	0.00%	225,000.00	225,000	100.00%
<b>TOTAL REVENUE &amp; INCOMING TRANSFERS</b>	<b>673,019.17</b>	<b>841,849</b>	<b>80.00%</b>	<b>928,190.16</b>	<b>1,460,556</b>	<b>64.00%</b>
EXPENDITURES	550,166.40	805,878	68.00%	413,785.35	1,593,169	26.00%
OUTGOING TRANSFERS	150,000.00	150,000	100.00%	.00	150,000	0.00%
<b>TOTAL EXPENDITURES &amp; OUTGOING TRANSFERS</b>	<b>700,166.40</b>	<b>955,878</b>	<b>73.00%</b>	<b>413,785.35</b>	<b>1,743,169</b>	<b>24.00%</b>
NET REVENUE OVER EXPENDITURES	( 27,147.23)	( 114,029)		514,404.81	( 282,613)	

### **FUND 203 - LOCAL STREETS**

REVENUES	273,260.30	370,551	74.00%	280,964.69	373,772	75.00%
INCOMING TRANSFERS	250,000.00	250,000	100.00%	150,000.00	300,000	50.00%
<b>TOTAL REVENUE &amp; INCOMING TRANSFERS</b>	<b>523,260.30</b>	<b>620,551</b>	<b>84.00%</b>	<b>430,964.69</b>	<b>673,772</b>	<b>64.00%</b>
EXPENDITURES	500,565.19	688,525	73.00%	469,385.01	721,691	65.00%
OUTGOING TRANSFERS						
<b>TOTAL EXPENDITURES &amp; OUTGOING TRANSFERS</b>	<b>500,565.19</b>	<b>688,525</b>	<b>73.00%</b>	<b>469,385.01</b>	<b>721,691</b>	<b>65.00%</b>
NET REVENUE OVER EXPENDITURES	22,695.11	( 67,974)		( 38,420.32)	( 47,919)	

# CITY OF HASTINGS

## SUMMARY REVENUES AND EXPENDITURES COMPARED TO BUDGET FOR THE 10 MONTHS ENDING APRIL 30, 2026

	THIS YEAR FISCAL YTD 30-APR-26	REVISED BUDGET 2025-2026	FISCAL YTD % OF BUDGET	LAST YEAR FISCAL YTD 30-APR-25	REVISED BUDGET 2024-2025	FISCAL YTD % OF BUDGET
<b><i>FUND 209 - CEMETERY FUND</i></b>						
REVENUES	234,575.22	235,401	100.00%	232,283.17	273,779	85.00%
INCOMING TRANSFERS						
<b>TOTAL REVENUE &amp; INCOMING TRANSFERS</b>	<b>234,575.22</b>	<b>235,401</b>	<b>100.00%</b>	<b>232,283.17</b>	<b>273,779</b>	<b>85.00%</b>
EXPENDITURES	119,777.75	178,883	67.00%	222,738.63	312,362	71.00%
OUTGOING TRANSFERS						
<b>TOTAL EXPENDITURES &amp; OUTGOING TRANSFERS</b>	<b>119,777.75</b>	<b>178,883</b>	<b>67.00%</b>	<b>222,738.63</b>	<b>312,362</b>	<b>71.00%</b>
 NET REVENUE OVER EXPENDITURES	 <b>114,797.47</b>	 <b>56,518</b>		 <b>9,544.54</b>	 <b>( 38,583)</b>	

# CITY OF HASTINGS

## SUMMARY REVENUES AND EXPENDITURES COMPARED TO BUDGET FOR THE 10 MONTHS ENDING APRIL 30, 2026

	THIS YEAR FISCAL YTD 30-APR-26	REVISED BUDGET 2025-2026	FISCAL YTD % OF BUDGET	LAST YEAR FISCAL YTD 30-APR-25	REVISED BUDGET 2024-2025	FISCAL YTD % OF BUDGET
<b><i>FUND 243 - BROWNFIELD REDEVELOPMENT AUTH</i></b>						
REVENUES	97,430.98	140,450	69.00%	143,963.73	63,200	228.00%
INCOMING TRANSFERS						
TOTAL REVENUE & INCOMING TRANSFERS	97,430.98	140,450	69.00%	143,963.73	63,200	228.00%
EXPENDITURES	39,187.34	41,000	96.00%	.00	45,000	0.00%
OUTGOING TRANSFERS						
TOTAL EXPENDITURES & OUTGOING TRANSFERS	39,187.34	41,000	96.00%	.00	45,000	0.00%
NET REVENUE OVER EXPENDITURES	58,243.64	99,450		143,963.73	18,200	

# CITY OF HASTINGS

## SUMMARY REVENUES AND EXPENDITURES COMPARED TO BUDGET FOR THE 10 MONTHS ENDING APRIL 30, 2026

THIS YEAR FISCAL YTD 30-APR-26	REVISED BUDGET 2025-2026	FISCAL YTD % OF BUDGET	LAST YEAR FISCAL YTD 30-APR-25	REVISED BUDGET 2024-2025	FISCAL YTD % OF BUDGET
--------------------------------------	--------------------------------	------------------------------	--------------------------------------	--------------------------------	------------------------------

### *FUND 248 - DOWNTOWN DEVELOPMENT AUTHORITY*

REVENUES	1,204,823.84	836,300	144.00%	1,081,387.00	807,950	134.00%
INCOMING TRANSFERS						
<b>TOTAL REVENUE &amp; INCOMING TRANSFERS</b>	<b>1,204,823.84</b>	<b>836,300</b>	<b>144.00%</b>	<b>1,081,387.00</b>	<b>807,950</b>	<b>134.00%</b>
EXPENDITURES	674,490.87	789,229	85.00%	1,642,724.37	883,391	186.00%
OUTGOING TRANSFERS						
<b>TOTAL EXPENDITURES &amp; OUTGOING TRANSFERS</b>	<b>674,490.87</b>	<b>789,229</b>	<b>85.00%</b>	<b>1,642,724.37</b>	<b>883,391</b>	<b>186.00%</b>
NET REVENUE OVER EXPENDITURES	<b>530,332.97</b>	<b>47,071</b>		<b>( 561,337.37)</b>	<b>( 75,441)</b>	

# CITY OF HASTINGS

## SUMMARY REVENUES AND EXPENDITURES COMPARED TO BUDGET FOR THE 10 MONTHS ENDING APRIL 30, 2026

	THIS YEAR FISCAL YTD 30-APR-26	REVISED BUDGET 2025-2026	FISCAL YTD % OF BUDGET	LAST YEAR FISCAL YTD 30-APR-25	REVISED BUDGET 2024-2025	FISCAL YTD % OF BUDGET
--	--------------------------------------	--------------------------------	------------------------------	--------------------------------------	--------------------------------	------------------------------

### *FUND 265 - DRUG ENFORCEMENT*

REVENUES	5.00	0	0.00%	30.00	2,500	1.00%
INCOMING TRANSFERS						
<b>TOTAL REVENUE &amp; INCOMING TRANSFERS</b>	<u>5.00</u>	<u>0</u>	<u>0.00%</u>	<u>30.00</u>	<u>2,500</u>	<u>1.00%</u>
EXPENDITURES	4,546.60	5,000	91.00%	( 480.00)	5,600	(9.00%)
OUTGOING TRANSFERS						
<b>TOTAL EXPENDITURES &amp; OUTGOING TRANSFERS</b>	<u>4,546.60</u>	<u>5,000</u>	<u>91.00%</u>	<u>( 480.00)</u>	<u>5,600</u>	<u>(9.00%)</u>
<b>NET REVENUE OVER EXPENDITURES</b>	<u>( 4,541.60)</u>	<u>( 5,000)</u>		<u>510.00</u>	<u>( 3,100)</u>	

### *FUND 266 - POLICE TRAINING*

REVENUES	6,247.17	3,600	174.00%	1,606.38	3,400	47.00%
INCOMING TRANSFERS						
<b>TOTAL REVENUE &amp; INCOMING TRANSFERS</b>	<u>6,247.17</u>	<u>3,600</u>	<u>174.00%</u>	<u>1,606.38</u>	<u>3,400</u>	<u>47.00%</u>
EXPENDITURES	2,593.43	6,800	38.00%	2,872.11	4,900	59.00%
OUTGOING TRANSFERS						
<b>TOTAL EXPENDITURES &amp; OUTGOING TRANSFERS</b>	<u>2,593.43</u>	<u>6,800</u>	<u>38.00%</u>	<u>2,872.11</u>	<u>4,900</u>	<u>59.00%</u>
<b>NET REVENUE OVER EXPENDITURES</b>	<u>3,653.74</u>	<u>( 3,200)</u>		<u>( 1,265.73)</u>	<u>( 1,500)</u>	

# CITY OF HASTINGS

## SUMMARY REVENUES AND EXPENDITURES COMPARED TO BUDGET FOR THE 10 MONTHS ENDING APRIL 30, 2026

THIS YEAR FISCAL YTD 30-APR-26	REVISED BUDGET 2025-2026	FISCAL YTD % OF BUDGET	LAST YEAR FISCAL YTD 30-APR-25	REVISED BUDGET 2024-2025	FISCAL YTD % OF BUDGET
--------------------------------------	--------------------------------	------------------------------	--------------------------------------	--------------------------------	------------------------------

### *FUND 271 - LIBRARY FUND*

#### **OPERATIONS**

---

OPERATING REVENUES	865,852.23	709,941	122.00%	749,655.24	673,516	111.00%
OPERATING INCOMING TRANSFERS						
<b>TOTAL OPERATING REV &amp; IN TRNSFRS</b>	<b>865,852.23</b>	<b>709,941</b>	<b>122.00%</b>	<b>749,655.24</b>	<b>673,516</b>	<b>111.00%</b>
OPERATING EXPENDITURES	579,928.75	713,969	81.00%	591,158.06	656,799	90.00%
OPERATING OUTGOING TRANSFERS						
<b>TOTAL OPERATING EXP &amp; OUT TRNSFRS</b>	<b>579,928.75</b>	<b>713,969</b>	<b>81.00%</b>	<b>591,158.06</b>	<b>656,799</b>	<b>90.00%</b>
NET OPERATING REV OVER EXP	285,923.48	( 4,028)		158,497.18	16,717	

#### **CAPITAL IMPROVEMENTS**

---

CAP IMPRVMT EXPENDITURES	.00	0	0.00%	.00	0	0.00%
CAP IMPRVMT OUTGOING TRANSFERS						
<b>TOTAL CAP IMPRVMT EXP &amp; OUT TRNSFRS</b>	<b>.00</b>	<b>0</b>	<b>0.00%</b>	<b>.00</b>	<b>0</b>	<b>0.00%</b>
NET CAP IMPRVMT REV OVER EXP	.00	0		.00	0	

# CITY OF HASTINGS

## SUMMARY REVENUES AND EXPENDITURES COMPARED TO BUDGET FOR THE 10 MONTHS ENDING APRIL 30, 2026

	THIS YEAR FISCAL YTD 30-APR-26	REVISED BUDGET 2025-2026	FISCAL YTD % OF BUDGET	LAST YEAR FISCAL YTD 30-APR-25	REVISED BUDGET 2024-2025	FISCAL YTD % OF BUDGET
<b><i>FUND 590 - SEWER FUND</i></b>						
REVENUES	2,615,877.66	2,998,142	87.00%	.00	0	0.00%
INCOMING TRANSFERS						
<b>TOTAL REVENUE &amp; INCOMING TRANSFERS</b>	<b>2,615,877.66</b>	<b>2,998,142</b>	<b>87.00%</b>	<b>.00</b>	<b>0</b>	<b>0.00%</b>
EXPENDITURES	1,851,876.47	2,521,814	73.00%	.00	0	0.00%
OUTGOING TRANSFERS	.00	0	0.00%	.00	0	0.00%
<b>TOTAL EXPENDITURES &amp; OUTGOING TRANSFERS</b>	<b>1,851,876.47</b>	<b>2,521,814</b>	<b>73.00%</b>	<b>.00</b>	<b>0</b>	<b>0.00%</b>
 NET REVENUE OVER EXPENDITURES	 764,001.19	 476,328		 .00	 0	

# CITY OF HASTINGS

## SUMMARY REVENUES AND EXPENDITURES COMPARED TO BUDGET FOR THE 10 MONTHS ENDING APRIL 30, 2026

	THIS YEAR FISCAL YTD 30-APR-26	REVISED BUDGET 2025-2026	FISCAL YTD % OF BUDGET	LAST YEAR FISCAL YTD 30-APR-25	REVISED BUDGET 2024-2025	FISCAL YTD % OF BUDGET
<b><i>FUND 591 - WATER FUND</i></b>						
REVENUES	1,700,515.98	1,919,400	89.00%	.00	0	0.00%
INCOMING TRANSFERS						
<b>TOTAL REVENUE &amp; INCOMING TRANSFERS</b>	<b>1,700,515.98</b>	<b>1,919,400</b>	<b>89.00%</b>	<b>.00</b>	<b>0</b>	<b>0.00%</b>
EXPENDITURES	1,528,603.00	2,257,234	68.00%	.00	0	0.00%
OUTGOING TRANSFERS	.00	0	0.00%	.00	0	0.00%
<b>TOTAL EXPENDITURES &amp; OUTGOING TRANSFERS</b>	<b>1,528,603.00</b>	<b>2,257,234</b>	<b>68.00%</b>	<b>.00</b>	<b>0</b>	<b>0.00%</b>
 NET REVENUE OVER EXPENDITURES	 <b>171,912.98</b>	 <b>( 337,834)</b>		 <b>.00</b>	 <b>0</b>	

# CITY OF HASTINGS

## SUMMARY REVENUES AND EXPENDITURES COMPARED TO BUDGET FOR THE 10 MONTHS ENDING APRIL 30, 2026

	THIS YEAR FISCAL YTD 30-APR-26	REVISED BUDGET 2025-2026	FISCAL YTD % OF BUDGET	LAST YEAR FISCAL YTD 30-APR-25	REVISED BUDGET 2024-2025	FISCAL YTD % OF BUDGET
<i><b>FUND 661 - EQUIPMENT REVOLVING FUND</b></i>						
REVENUES	792,027.42	870,000	91.00%	732,859.15	908,000	81.00%
INCOMING TRANSFERS						
<b>TOTAL REVENUE &amp; INCOMING TRANSFERS</b>	<b>792,027.42</b>	<b>870,000</b>	<b>91.00%</b>	<b>732,859.15</b>	<b>908,000</b>	<b>81.00%</b>
EXPENDITURES	403,457.71	534,080	76.00%	418,261.48	626,963	67.00%
OUTGOING TRANSFERS						
<b>TOTAL EXPENDITURES &amp; OUTGOING TRANSFERS</b>	<b>403,457.71</b>	<b>534,080</b>	<b>76.00%</b>	<b>418,261.48</b>	<b>626,963</b>	<b>67.00%</b>
 NET REVENUE OVER EXPENDITURES	 <b>388,569.71</b>	 <b>335,920</b>		 <b>314,597.67</b>	 <b>281,037</b>	



# Hastings City Council Memorandum

**Date:** May 21, 2026  
**To:** Honorable Mayor Tossava & Members of the Hastings City Council  
**From:** Dan King, Community Development Director  
**Subject:** May Community Development Department Report

A summary of the current activities in the Community Development Department includes:

## DDA Strategic Plan

Double Haul Solutions has completed the DDA strategic plan and provided the DDA members with copies of the plan.

## State Street Corridor West of Broadway

The State Street corridor committee will be reconvening to discuss the results of the public engagement activities conducted by Progressive Companies.

## DDA Façade Grant

The DDA approved a façade grant for 139 E. Court Street. The building will be converted from a restaurant to a bourbon/wine/cigar lounge.

## Hastings Riverwalk Lofts

With construction on the Hastings Riverwalk Lofts at 328 and 420 E. Mill Street progressing, leasing applications are now being accepted. For more information, feel free to use the following links: [contact@hastingsriverwalklofts.com](mailto:contact@hastingsriverwalklofts.com) or [www.hastingsriverwalkslofts.com](http://www.hastingsriverwalkslofts.com). Information is also available by calling 616-306-9330.

## **Woodlawn Meadows Planned Unit Development**

Site balancing and site preparation continues on the Woodlawn Meadows project that will deliver 32 residential home building sites to the northern end of North East Street.

## **Upcoming Events**

Hastings Live – City Band June 3 7:30 PM – 9:00 PM

Hastings Live – Playing at the Plaza June 4 11:00 AM to Noon

Hastings Live – Fridays at the Fountain June 5 Noon to 1:00 PM

Hastings Live – Friday Night Feature June 5 7:30 PM – 9:00 PM

Rock the Block Street Dance June 20 5:30 PM – 11:00 PM

If you have any questions, concerns, or ideas please feel free to contact Sandy, Allison or me at [sponsetto@hastingsmi.gov](mailto:sponsetto@hastingsmi.gov) [adevries@hastingsmi.gov](mailto:adevries@hastingsmi.gov) [dking@hastingsmi.gov](mailto:dking@hastingsmi.gov)

